

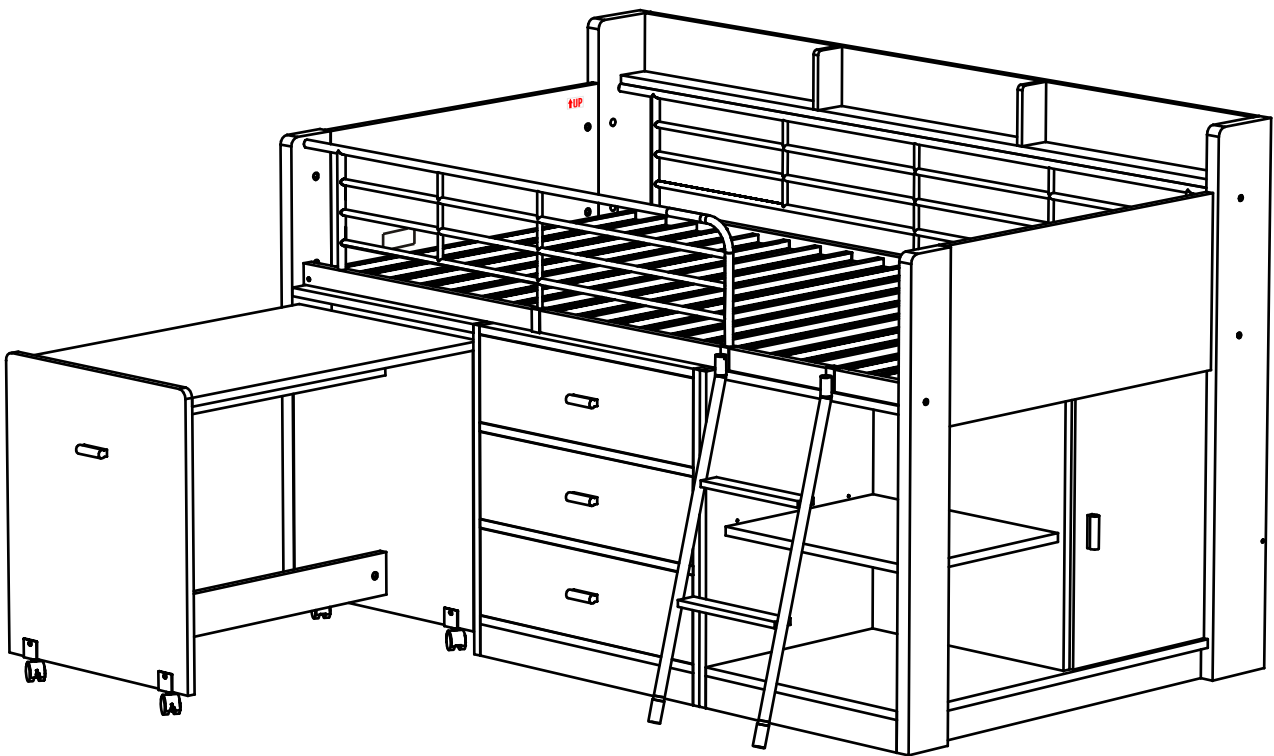

CHARLESTON LOFT BED

Thank you for choosing Rack Furniture. Before starting, we suggest reading through this instruction manual to ensure that you completely understand the assembly of this product.



Rack Furniture

Suite 1, 2713 SE I Street, Bentonville, AR 72712 USA

Customer Service: 1-479-715-6445

www.rackfurniturellc.com

WARNING

Safety First: Ensure that the top mattress fitted to this bed is no higher than the warning label attached to the safety rail assembly. IE: 6.30in (160mm) below the top of the safety rails.

Please note: Top bed is not recommended for children under six (6) years old.

- Allowing children to play on or below the beds is dangerous and jumping under any circumstances should be prohibited!
- The ladder is provided to allow easy access to the bed. Do Not allow children to get to the bed any other way.
- Ensure that you check regularly that all bolts are securely fastened and all components are in place. If spare parts are required, contact Rack Furniture at 1-479-715-6445 or write to us at 2713 SE I Street Bentonville, Arkansas 72712.
- **Do not** use product if any parts are missing.
- **Do not use substitute parts.**

Keep these instructions in a safe place for future use.

Caution: There are many small components used in the construction of this unit. These loose items should be kept away from young children while assembling your unit. As an extra precaution, screw cover caps should be permanently fixed in position. (Where applicable).

Two people will be required to assemble this unit.

Care and Maintenance:

To clean, use only mild household soap and warm water. Do not use bleach or detergent. Do not use abrasive cleaners which can scratch the finish of the product. Use clean soft cloths to wash, rinse and dry. With proper care, the quality finish will last a long time. Wood surfaces may be treated with light application of a good grade of non-toxic furniture polish.

Tools required for Assembly:

Rubber Hammer

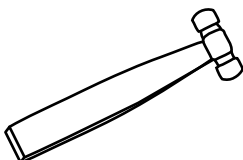

Phillips Screwdriver

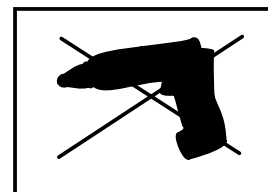

DO NOT USE POWER TOOLS TO ASSEMBLE THIS PRODUCT. USE OF POWER TOOLS WILL INVALIDATE ANY CLAIM AND MAY DAMAGE THIS PRODUCT MAKING IT UNSAFE.

PART LIST

Carton 1 of 3		
No.	Part Name	Pcs
①	Center Panel	1
②	Center Panel	1
④	Bottom Panel	1
⑦	Right Panel	1
⑧	Left Panel	1
⑪	Top Panel	1
⑱	Back Panel (Cabinet)	1
⑳	Front Panel (Desk)	1
㉓	Back Panel (Desk)	1
㉔	Top Panel (Desk)	1
㉕	Front Panel (Right)	1
㉖	Back Panel (Right)	1
㉗	Back Panel (Left)	1
㉘	Front Panel (Left)	1







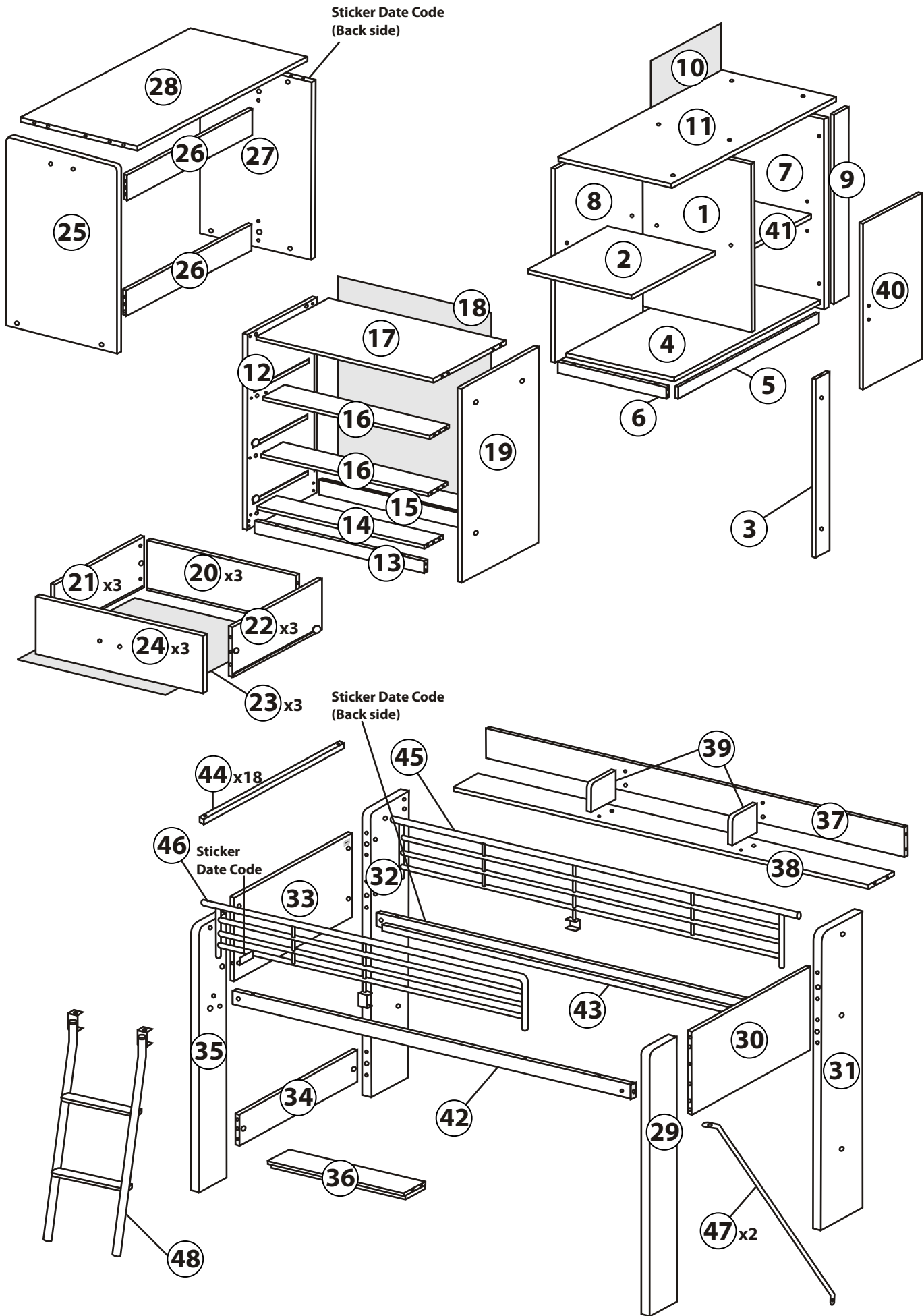

















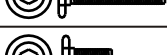

Carton 3 of 3		
No.	Part Name	Pcs
㉚	Side Rail (Front)	1
㉛	Side Rail (Rear)	1
㉜	K/D Slat Base	18
㉝	Guardrail (Long)	1
㉞	Guardrail (Short)	1
㉟	Brace	2
㊱	Ladder	1

Carton 2 of 3		
No.	Part Name	Pcs
③	Support Panel	1
⑤	Plinth Panel (Side)	1
⑥	Plinth Panel (Front)	1
⑨	Support Panel	1
⑩	Back Panel	1
⑫	Left Panel (Cabinet)	1
⑬	Plinth Panel (Cabinet)	1
⑭	Bottom Panel (Cabinet)	1
⑮	Back Support Panel (Cabinet)	1
⑯	Support Panel (Cabinet)	2
⑰	Top Panel (Cabinet)	1
⑲	Right Panel (Cabinet)	1
㉀	Back Panel (Drawers)	3
㉁	Left Panel (Drawers)	3
㉂	Right Panel (Drawers)	3
㉃	Bottom Panel (Drawers)	3
㉄	Front Panel (Drawers)	3
㉆	Support Panel (Desk)	2
㉈	Center Panel (Right)	1
㉉	Center Panel (Left)	1
㊱	Center Panel (Left)(Bottom)	1
㊳	Support Panel	1
㊴	Back Panel (Shelf)	1
㊵	Bottom Panel (Shelf)	1
㊶	Support Panel (Shelf)	2
㊷	Door	1
㊸	Movable Panel	1

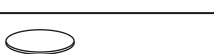
PART LIST



HARDWARE LIST

No.	Part Name		Pcs
(A)	Cam Bolt		46
(B)	Cam Lock		62
(C)	45mm Chipboard Screw		22
(D)	Solid Aluminum Handle (silver)		5
(E)	20mm Handle Screw		10
(F)	PVC Door Spring		2
(G)	Magnet		1
(H)	30mm Chipboard Screw		2
(I)	M6 x 25mm Allen Bolt (Silver)		5
(J)	U Shape Casters (Silver)		4
(K)	Dome Locking Nut		4
(L)	25mm Allen Bolt (Silver)		4
(M)	Metal Shelf Support		4
(N)	M8 x 95mm Allen Bolt (Silver)		4
(P)	M8 Round Nut		4
(Q)	M6 x 80mm Allen Bolt (Silver)		1
(R)	M6 x 70mm Allen Bolt (Silver)		3
(S)	M6 x 60mm Allen Bolt (Silver)		3
(T)	M6 x 50mm Allen Bolt (Silver)		1
(U)	M6 x 30mm Allen Bolt (Silver)		38
(V)	M6 x 12mm Allen Bolt (Silver)		4
(W)	M6 JCN Nut (Silver)		3
(X)	Double Ended Dowel		8
(Y)	Sticker		16
(Z)	M6 Allen Wrench		2
(Z1)	M8 Allen Wrench		1
(Z2)	M8 x 25mm PVC Dowel		128
(Z3)	14" Drawer Slide		3 Set
(Z4)	15mm Chipboard Screw		25

How to correctly install Cam Bolt and Lock

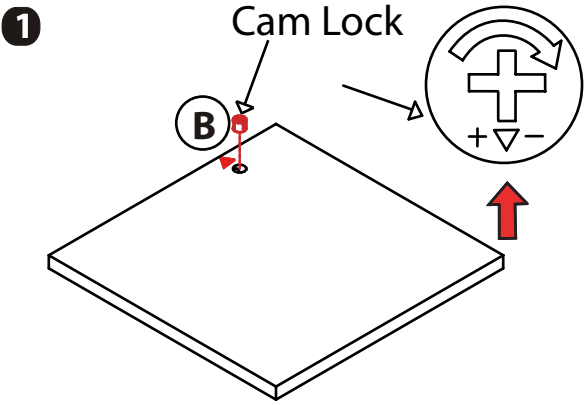

When fitting cam bolts into holes ensure that the arrow on the top of the cam points to the intersecting hole, which is usually on the nearest end edge of the panel.

INTERSECTING HOLE

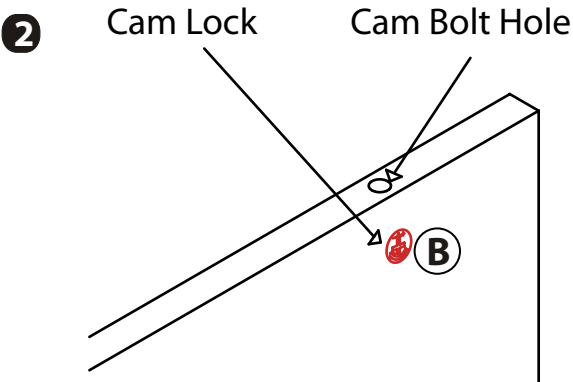
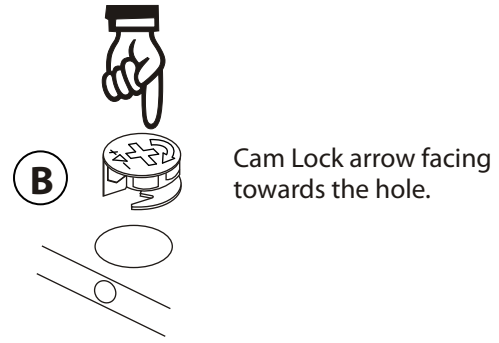

To fit two panels together the cam lock will slide into the intersecting hole, and into the cam.

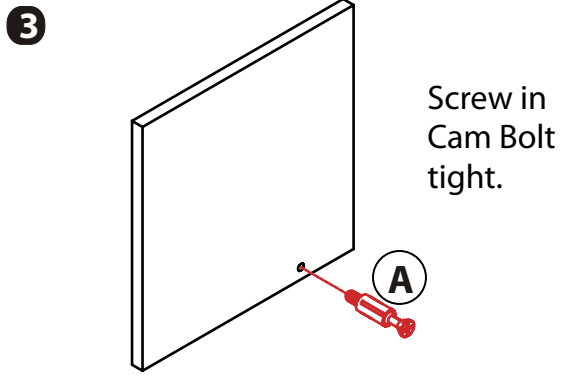

INTERSECTING HOLE

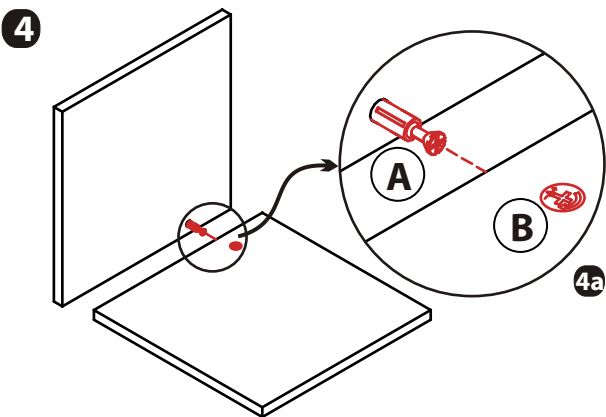
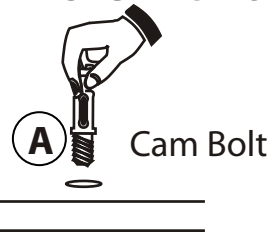

Insert Cam Bolt into Cam Lock hole. If Cam Bolt does not slide all the way in, check to make sure arrow on cam Lock is pointing toward cam bolt hole.

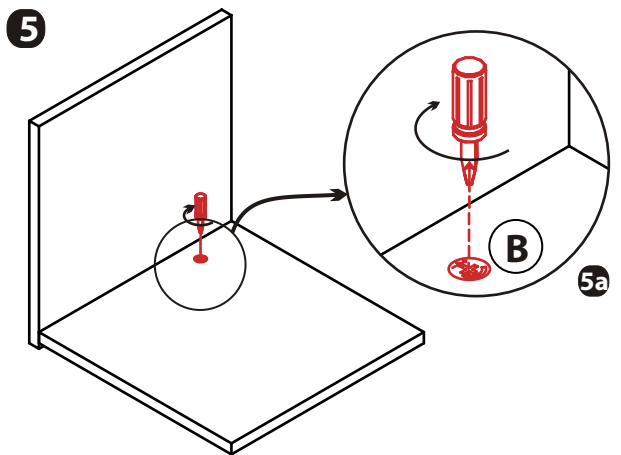

To secure simply turn the cam lock 180 Degrees in a clockwise direction, or until tight.

To Assembly the Drawer Slide, Please Follow Step as Below

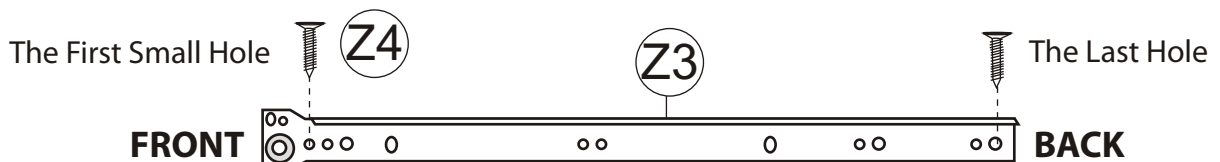

STEP 1 - DESK ASSEMBLY

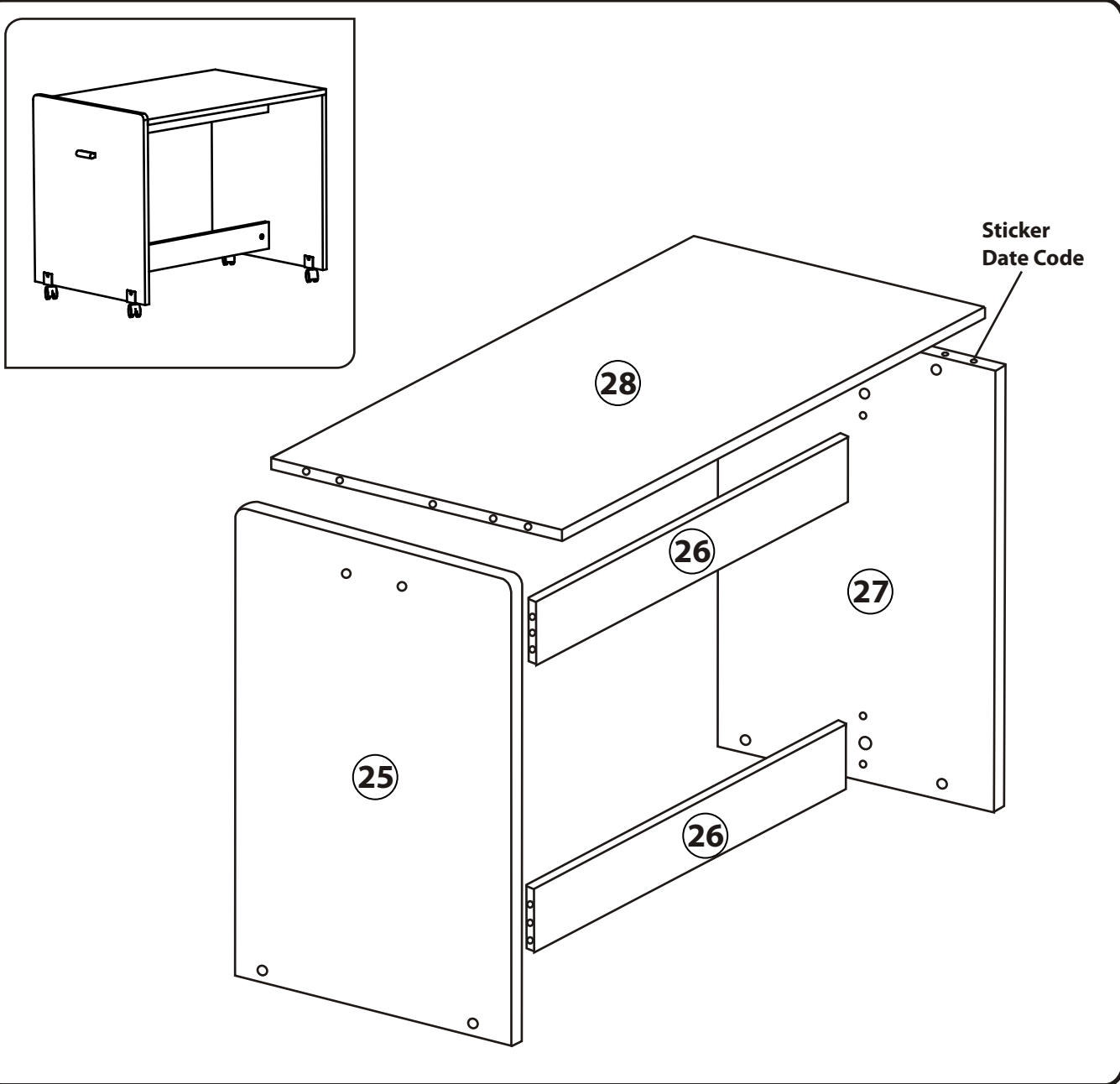

Hardware needed to assemble the Desk

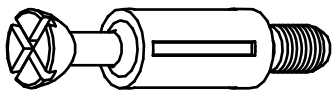

A (x8)

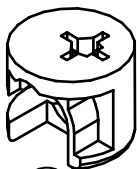

B (x8)



Z2 (x14)

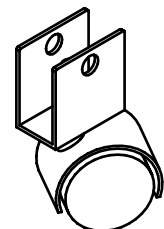

J (x4)



K (x4)

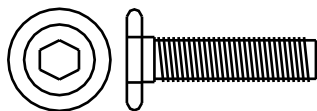

L (x4)

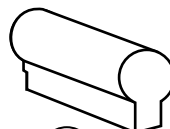

D (x1)



E (x2)

STEP 1 - DESK ASSEMBLY

Assemble the wood dowels, cam locks and cam Bolts first as per the diagram below.

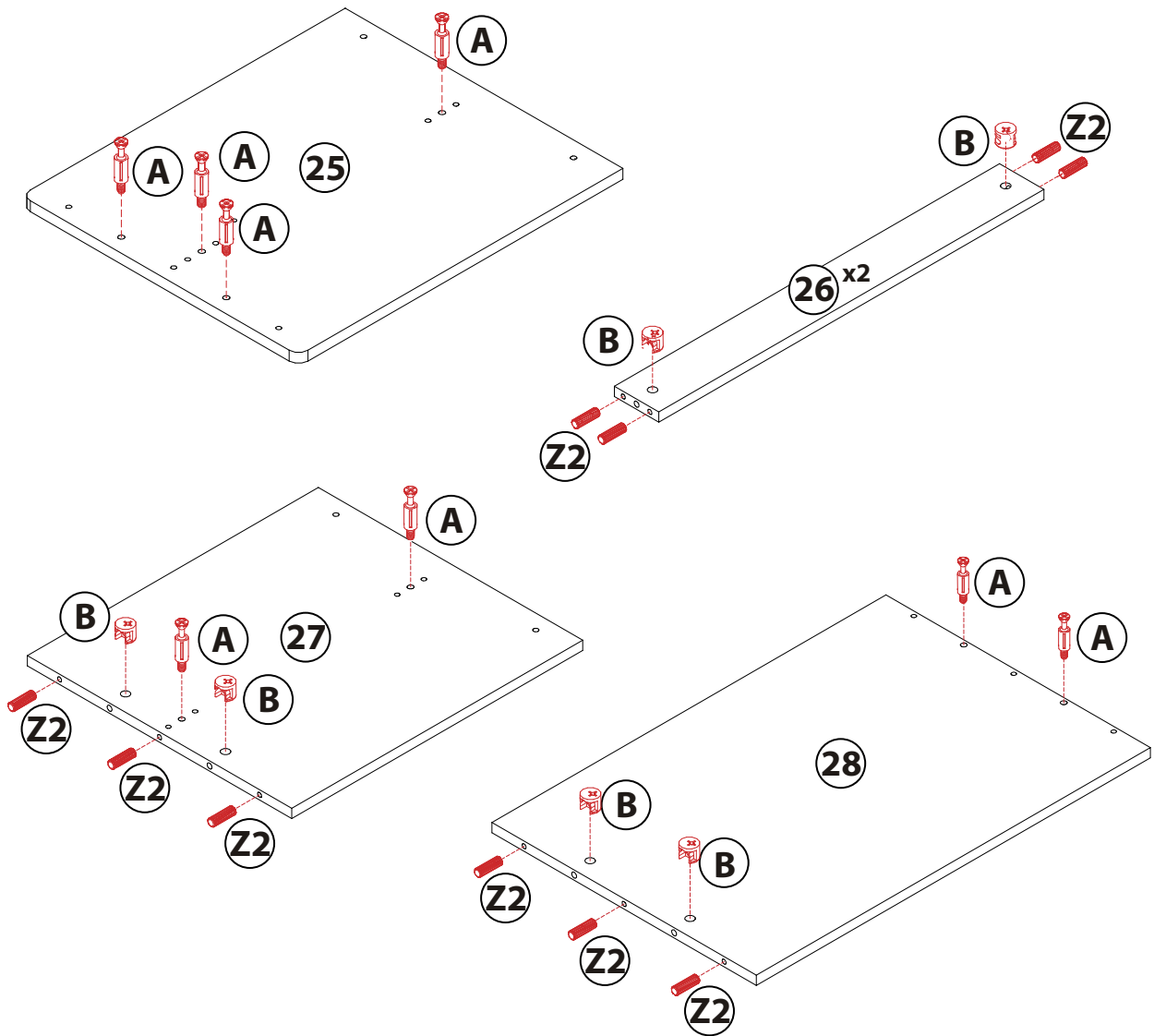

1-1

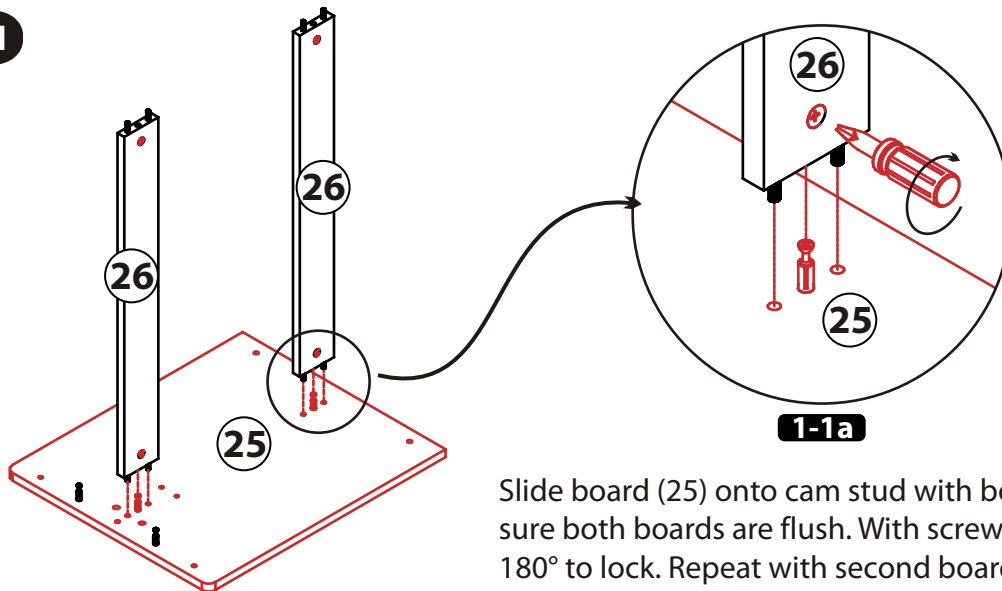

Slide board (25) onto cam stud with board (26), make sure both boards are flush. With screw driver turn cam 180° to lock. Repeat with second board (26).

STEP 1 - DESK ASSEMBLY

1-2

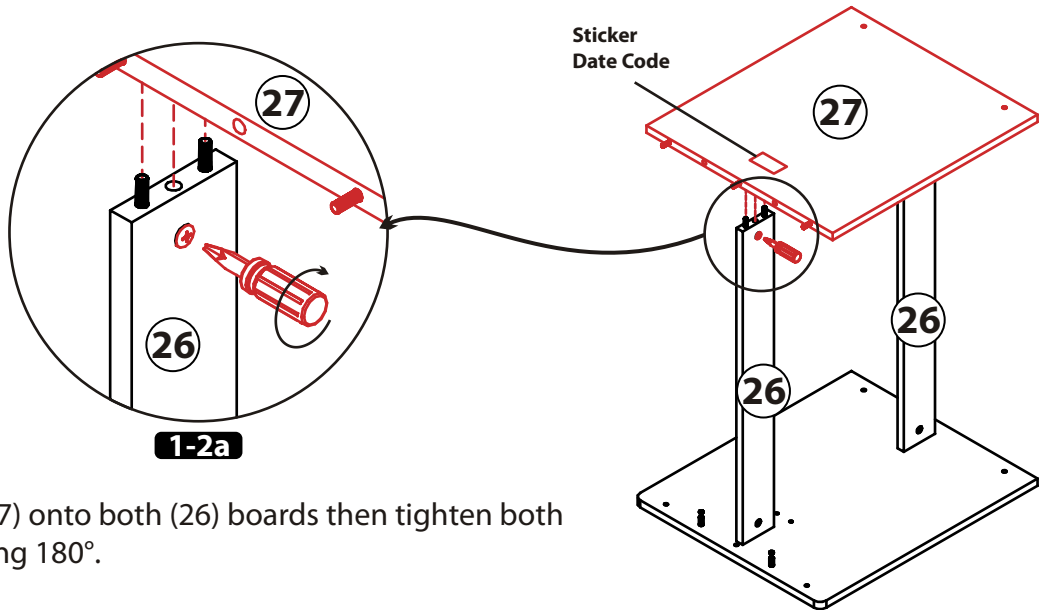

Slide board (27) onto both (26) boards then tighten both cams by turning 180°.

1-3

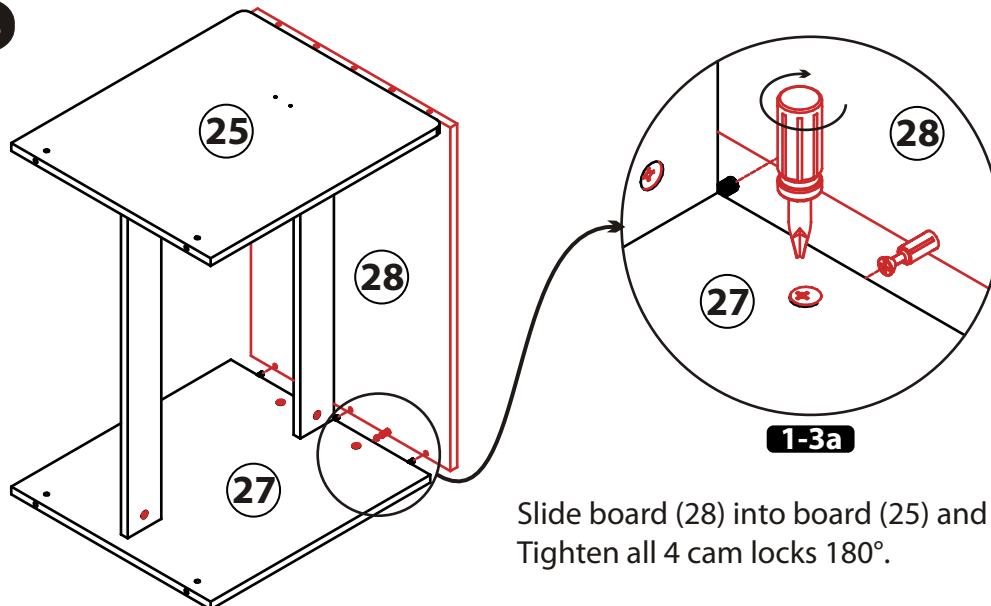

Slide board (28) into board (25) and onto board (27). Tighten all 4 cam locks 180°.

1-4

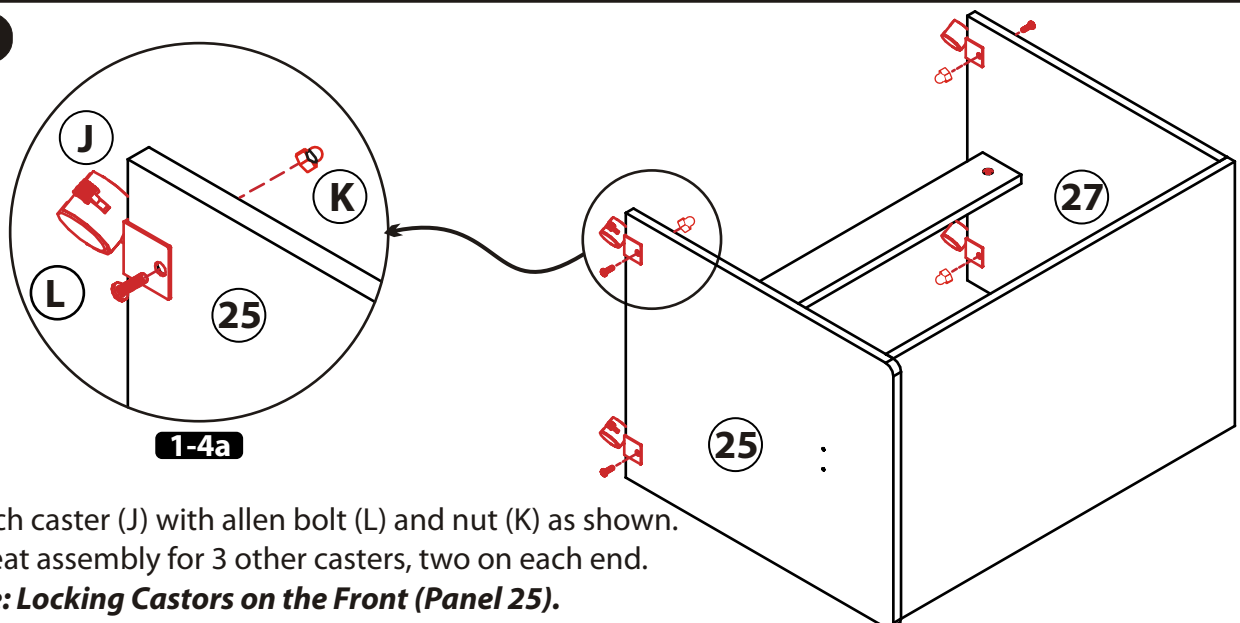

Attach caster (J) with allen bolt (L) and nut (K) as shown. Repeat assembly for 3 other casters, two on each end.

Note: Locking Castors on the Front (Panel 25).

STEP 1 - DESK ASSEMBLY

1-5

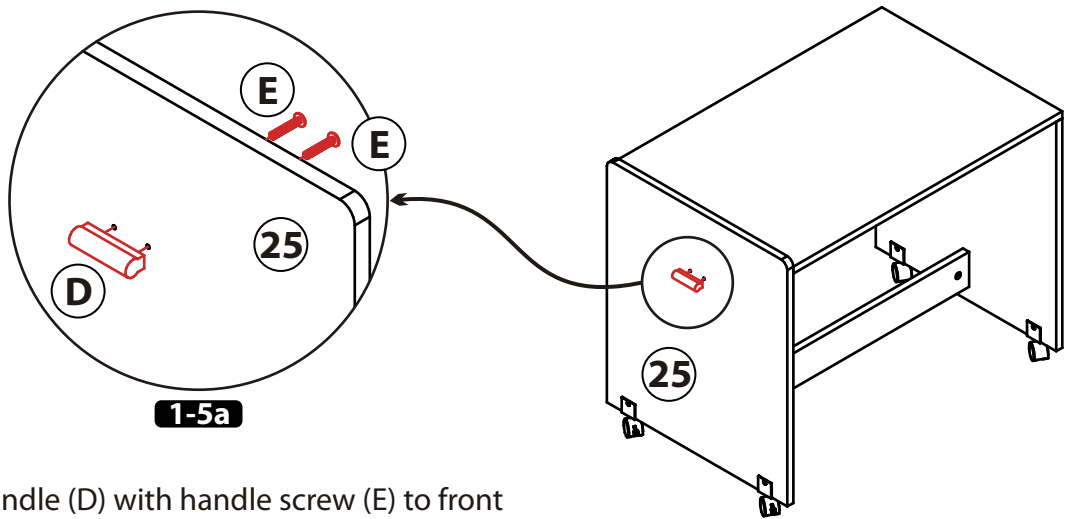

Attach handle (D) with handle screw (E) to front panel (25) as shown. Desk assembly complete.

STEP 2 - DRAWER AND CABINET ASSEMBLY

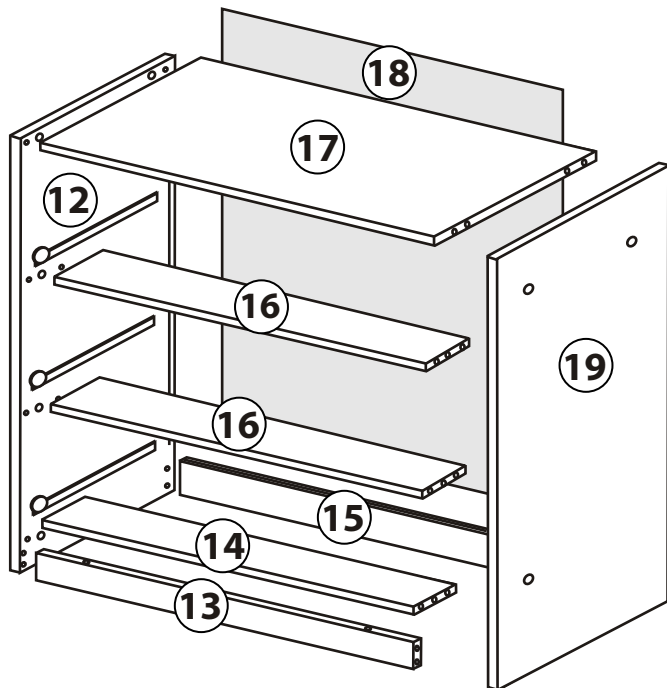
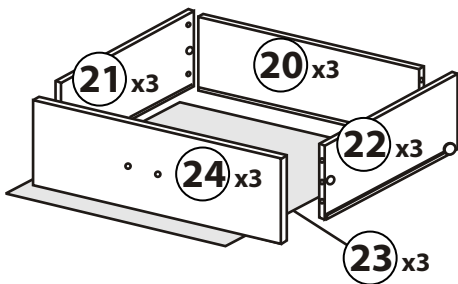
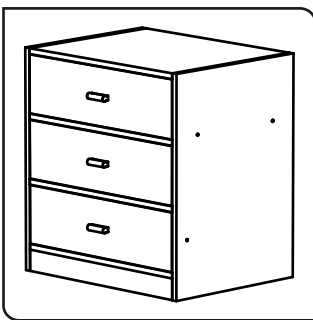

Hardware needed to assemble the Drawer and Cabinet

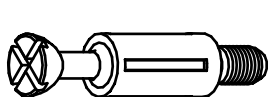

A (x25)



B (x24)



Z2 (x48)



D (x3)



E (x6)

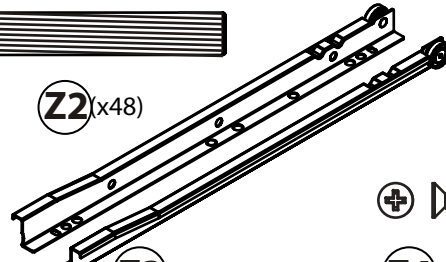

Z3 (3 set)



Z4 (x25)

STEP 2 - DRAWER & DRESSER ASSEMBLY

Assemble the wood dowels, cam locks and cam Bolts first as per the diagram below.

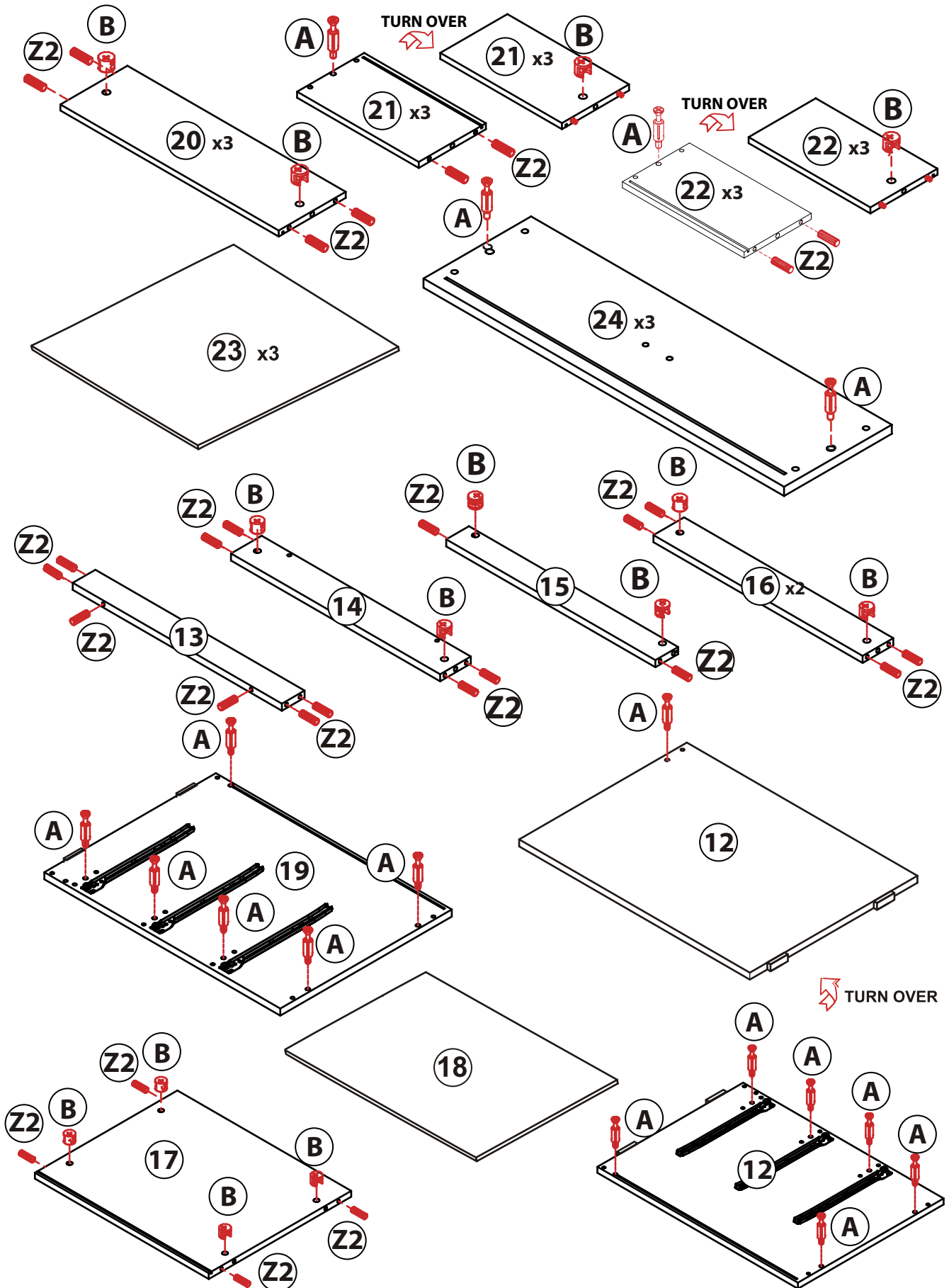

STEP 2 - DRAWER AND CABINET ASSEMBLY

2-1

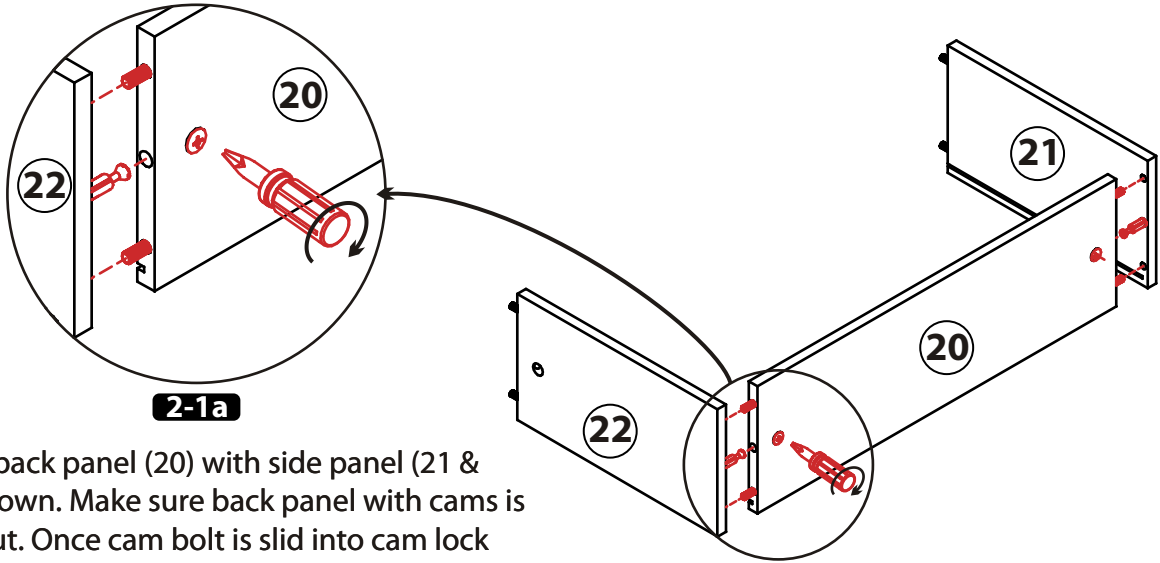

Tighten back panel (20) with side panel (21 & 22) as shown. Make sure back panel with cams is facing out. Once cam bolt is slid into cam lock then then turn cam lock 180° or until locked.

2-2

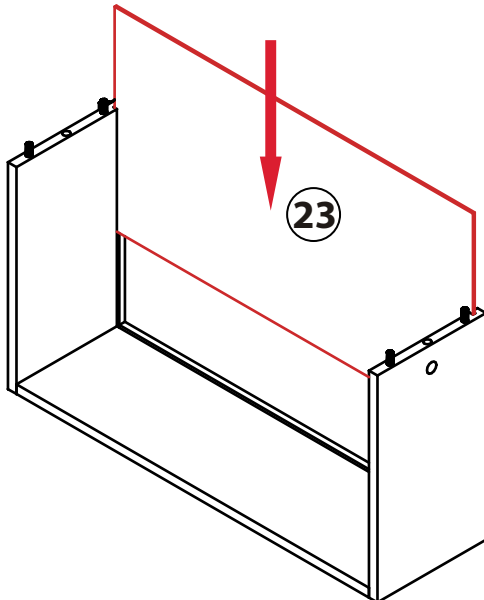

Insert bottom panel (23) as shown.

2-3

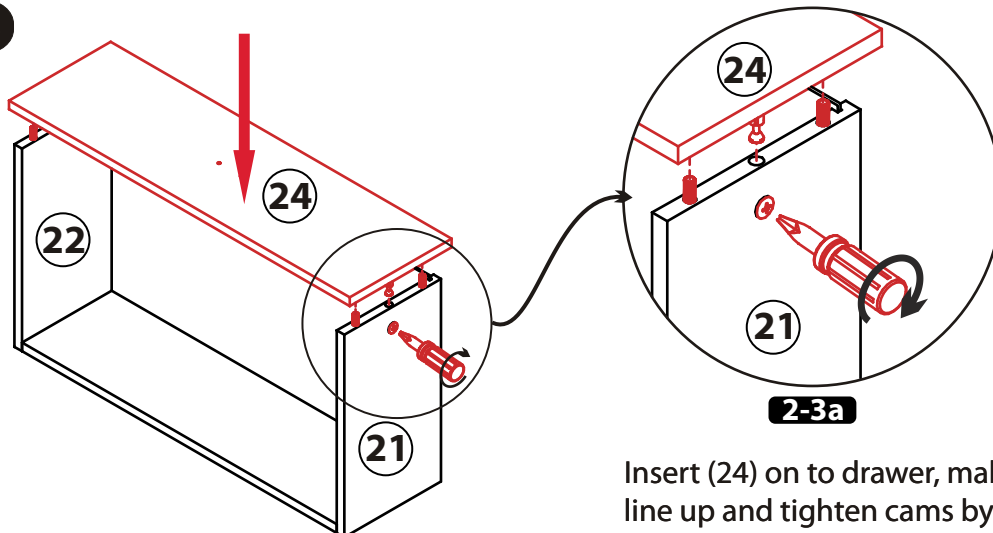

Insert (24) on to drawer, make sure all holes line up and tighten cams by turning 180° or until tight.

STEP 2 - DRAWER & DRESSER ASSEMBLY

2-4

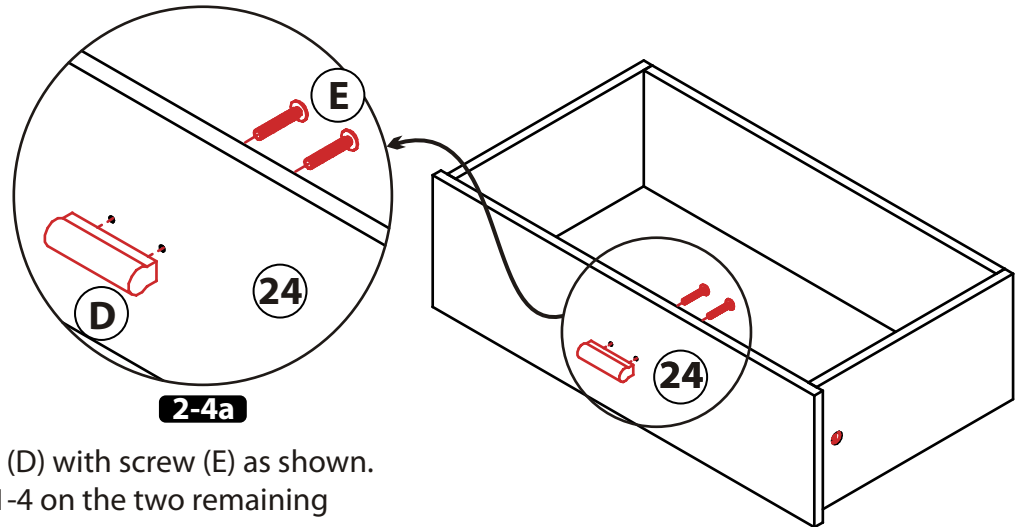

2-4a

Tighten handle (D) with screw (E) as shown. Repeat steps #1-4 on the two remaining drawers.

2-5

Fixing drawer slide (Z3) with Screw (Z4) as shown.

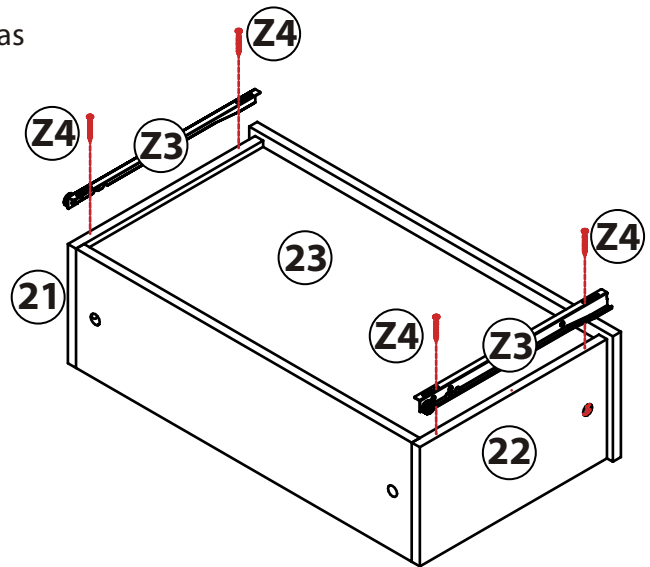
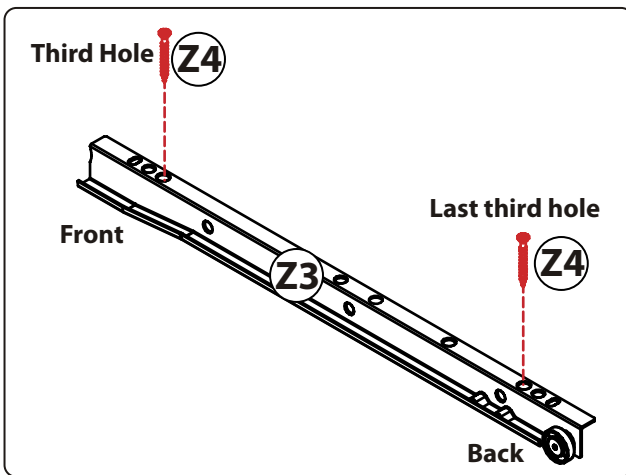

2-6

2-6a

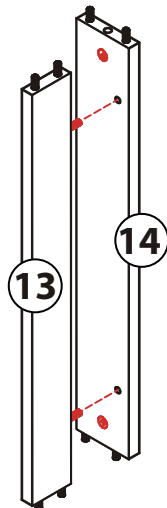

2-6b

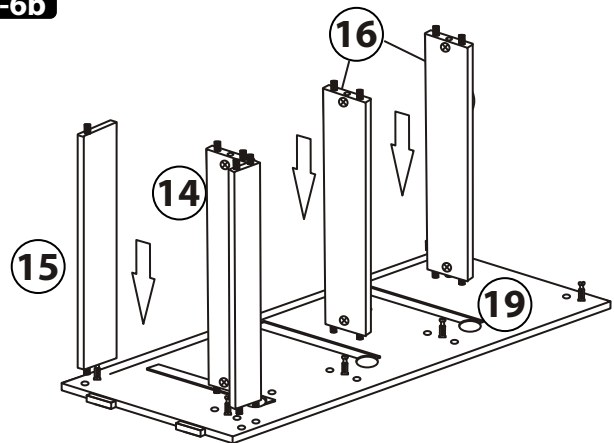

Attach (13) to bottom of (14). Put (14),(15) and both (16)'s in (19). Make sure all the cam locks face down or towards back of unit, then tighten.

STEP 2 - DRAWER & DRESSER ASSEMBLY

2-7

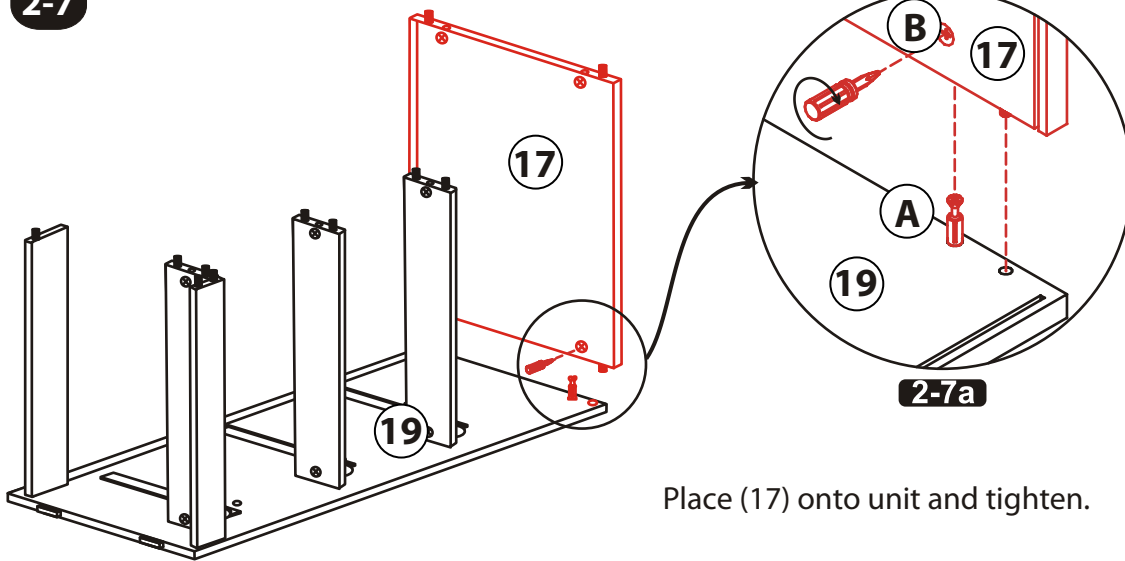

2-8

Insert back panel (18) into channels as shown.

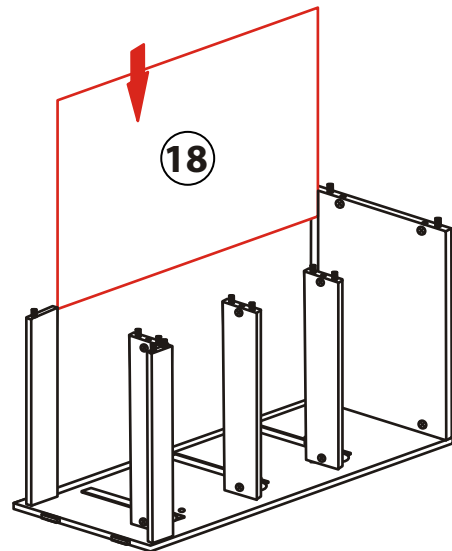

2-9

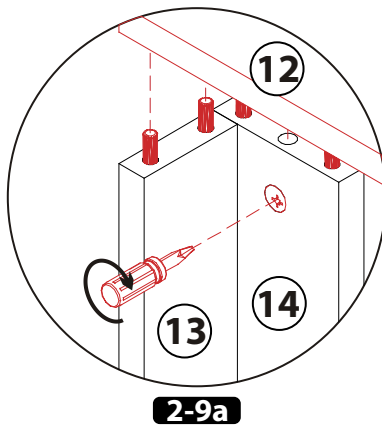

Make sure all cam studs line up. Tighten right panel (12) as shown, repeat for left panel (19). Dresser assembly complete.

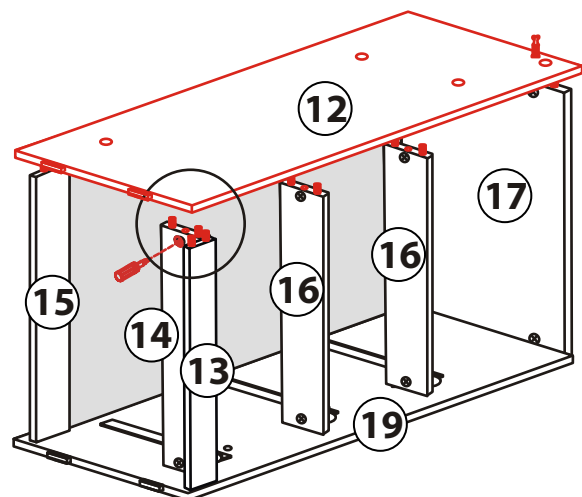

STEP 3 - SHELF ASSEMBLY

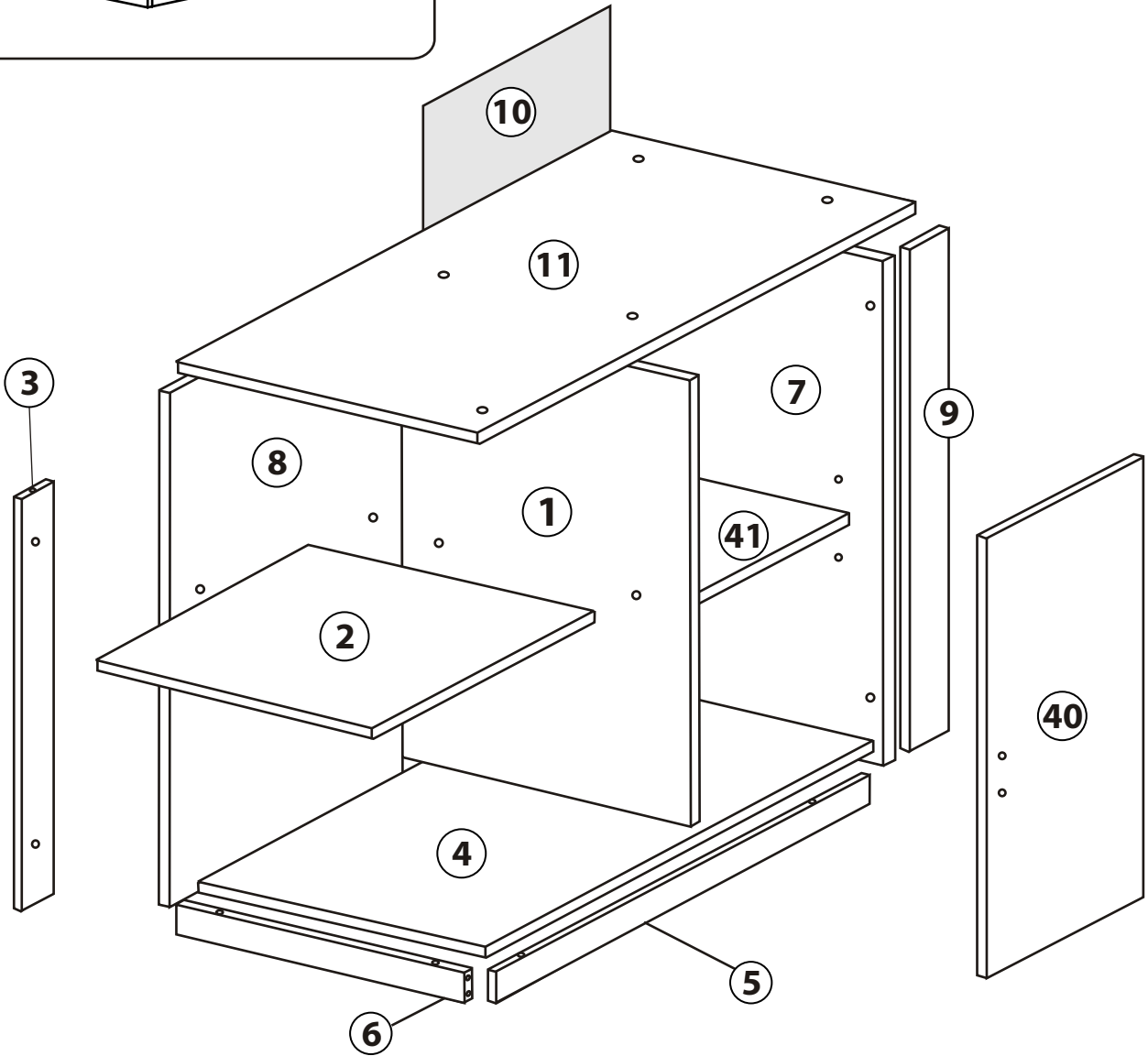
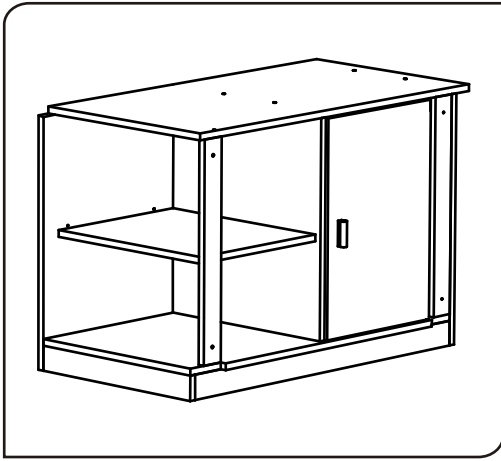

Hardware needed to assemble the Shelf

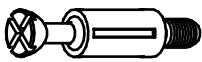

A (x6)



B (x6)



Z2 (x31)



C (x15)

STEP 3 - SHELF ASSEMBLY

Assemble the wood dowels, cam locks and cam Bolts first as per the diagram below.

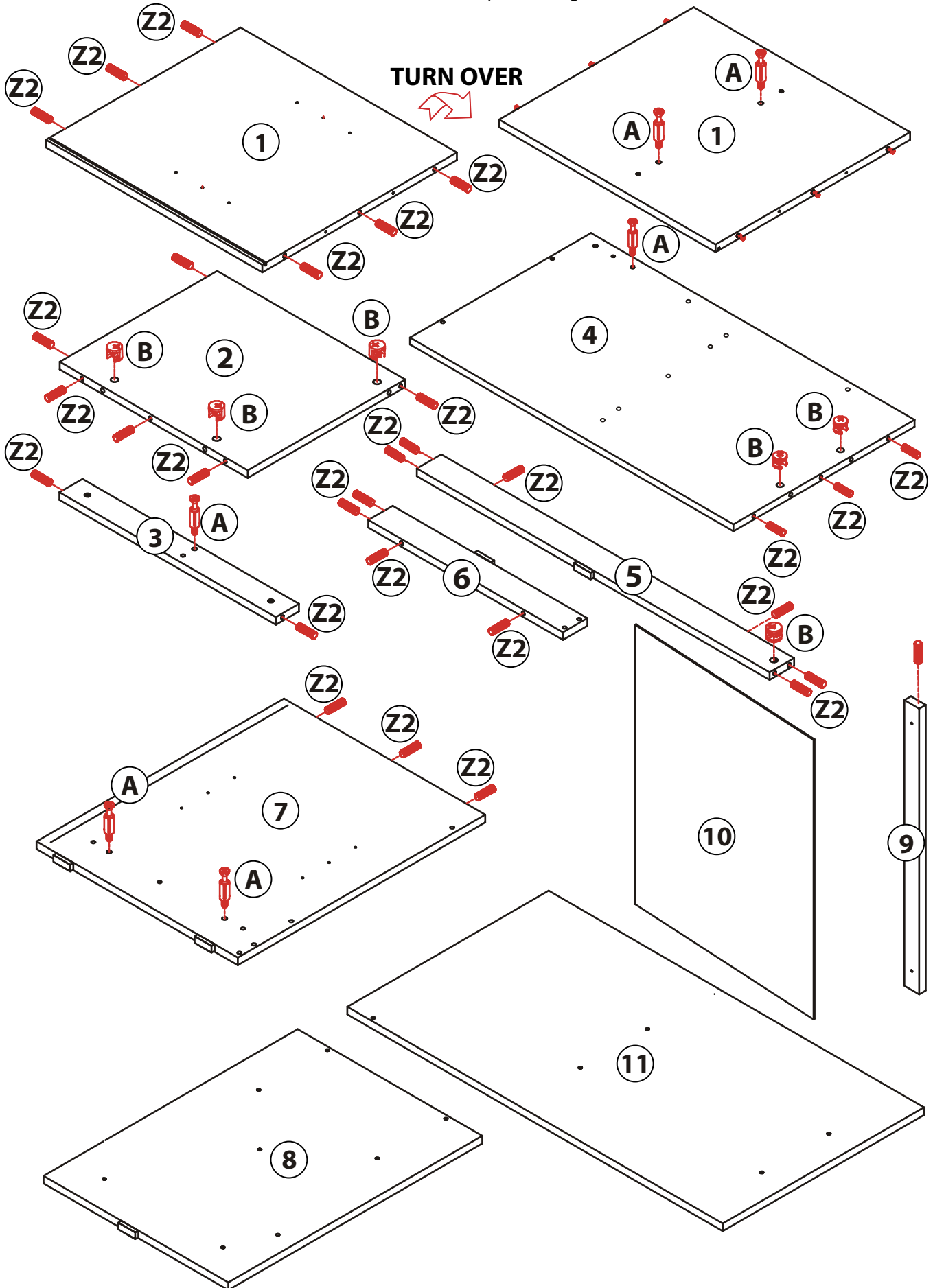

STEP 3 - SHELF ASSEMBLY

3-1

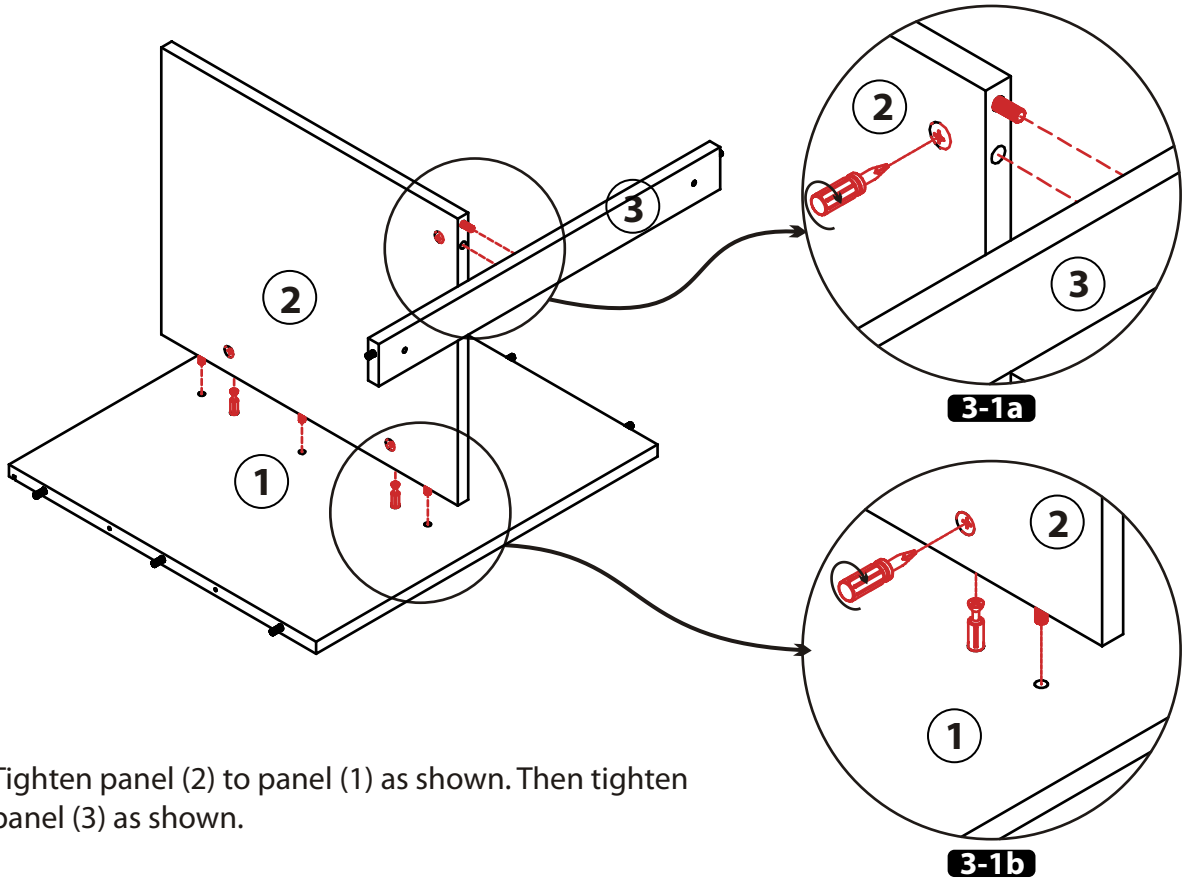

Tighten panel (2) to panel (1) as shown. Then tighten panel (3) as shown.

3-2

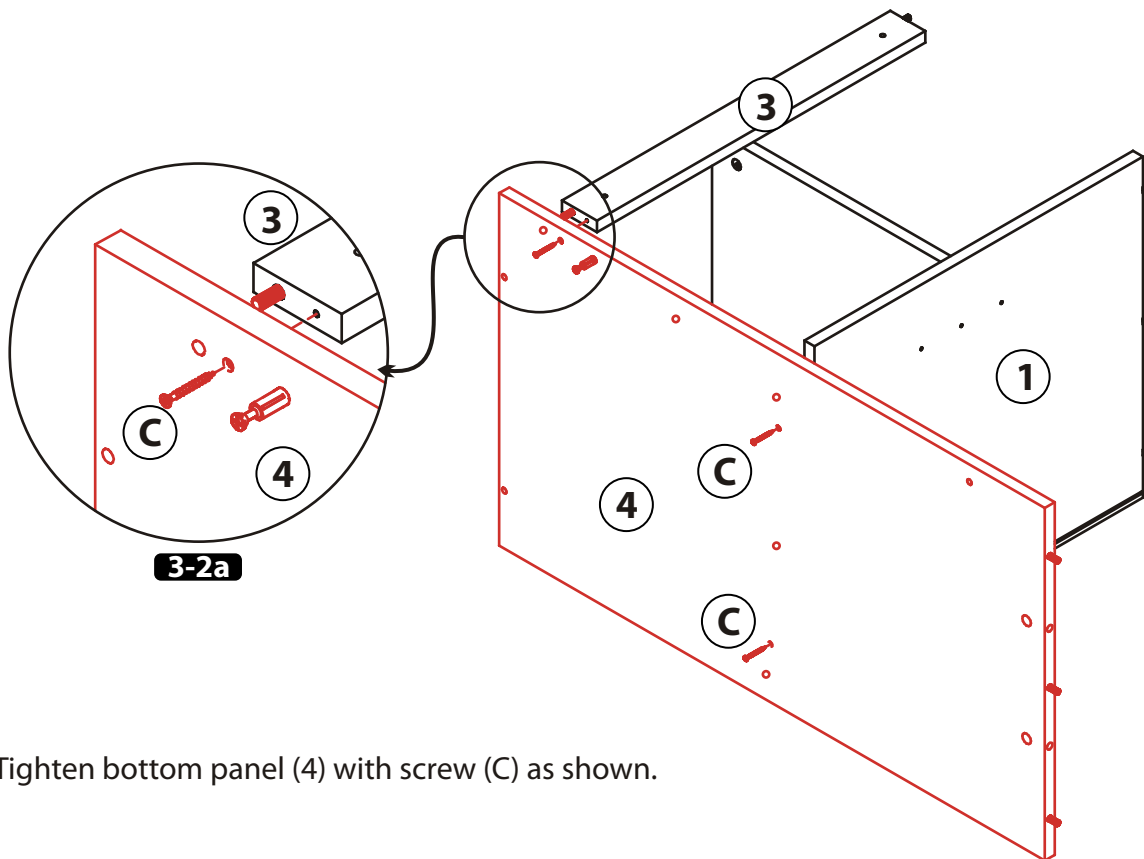

Tighten bottom panel (4) with screw (C) as shown.

STEP 3 - SHELF ASSEMBLY

3-3

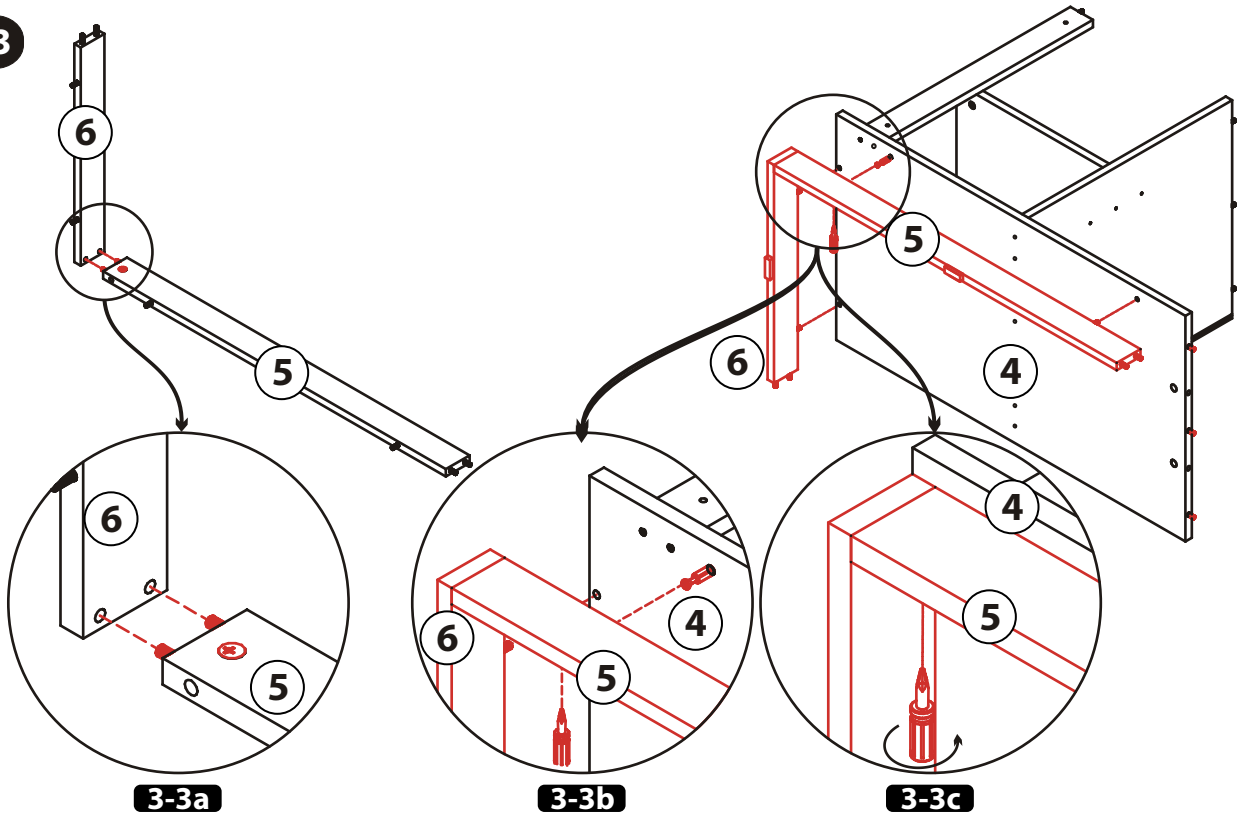

Push in panel (6) to the panel (5) as shown in 3-3a.

Push in panel (5 & 6) into bottom of panel (4). Then tighten to bottom panel as shown 3-3b & 3-3c.

3-4

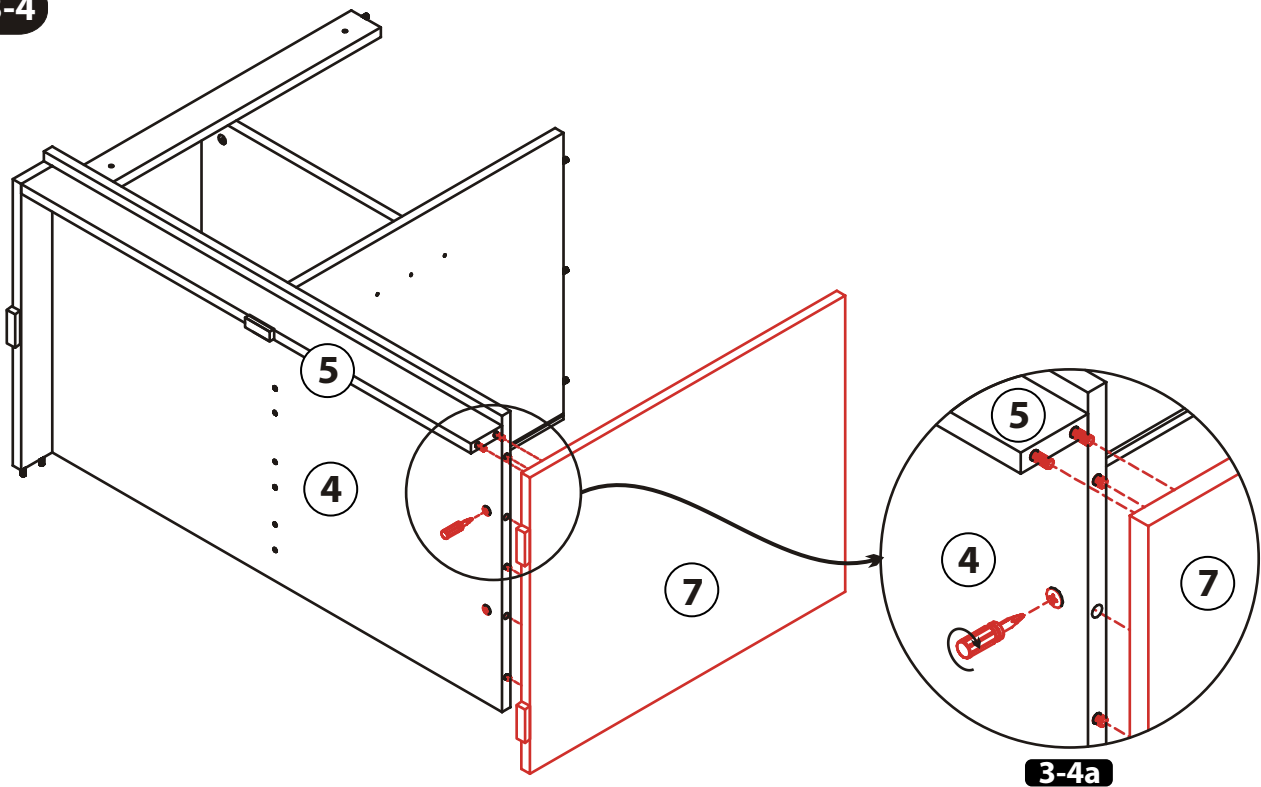

Tighten panel (7) as shown.

STEP 3 - SHELF ASSEMBLY

3-5

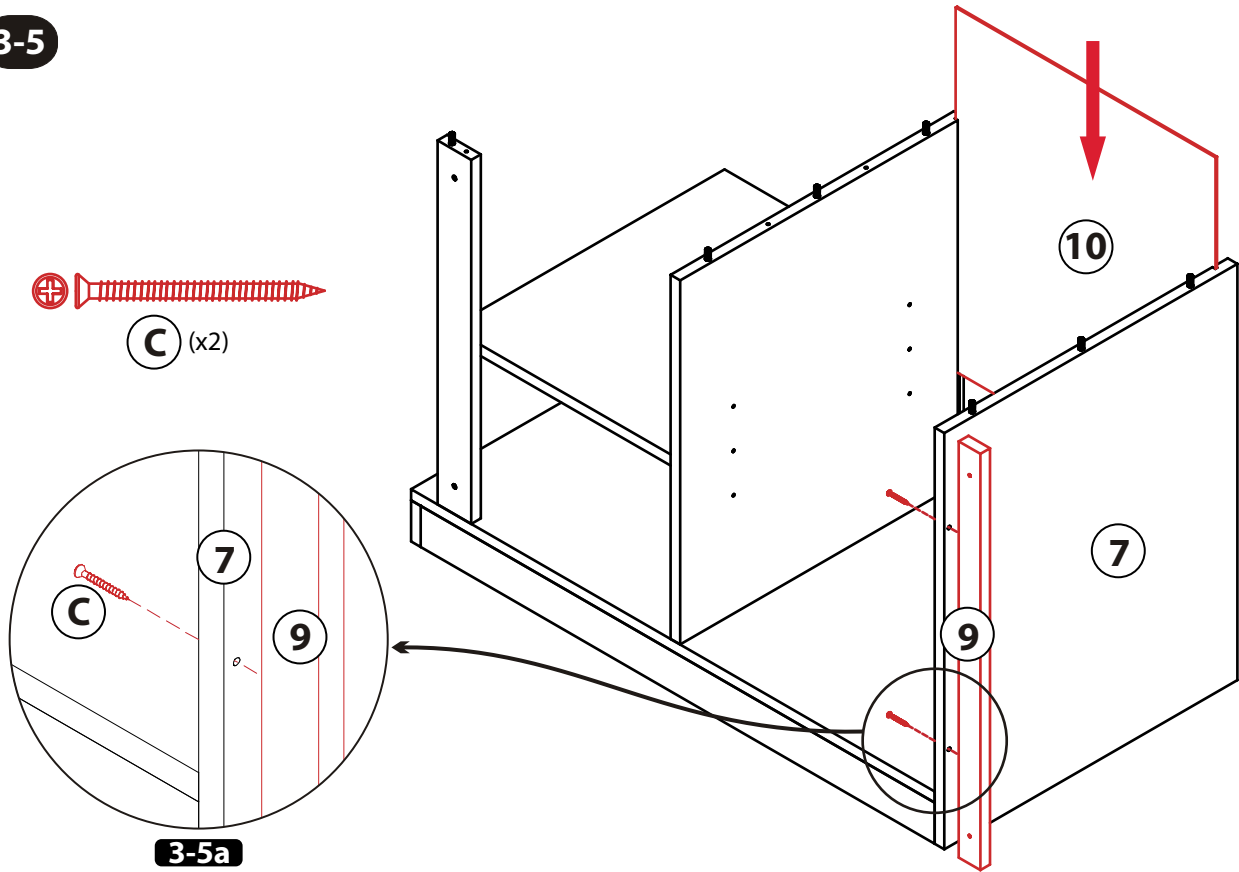

Push in back panel (10) as shown. Then tighten support panel (9) with screw (C) as shown.

3-6

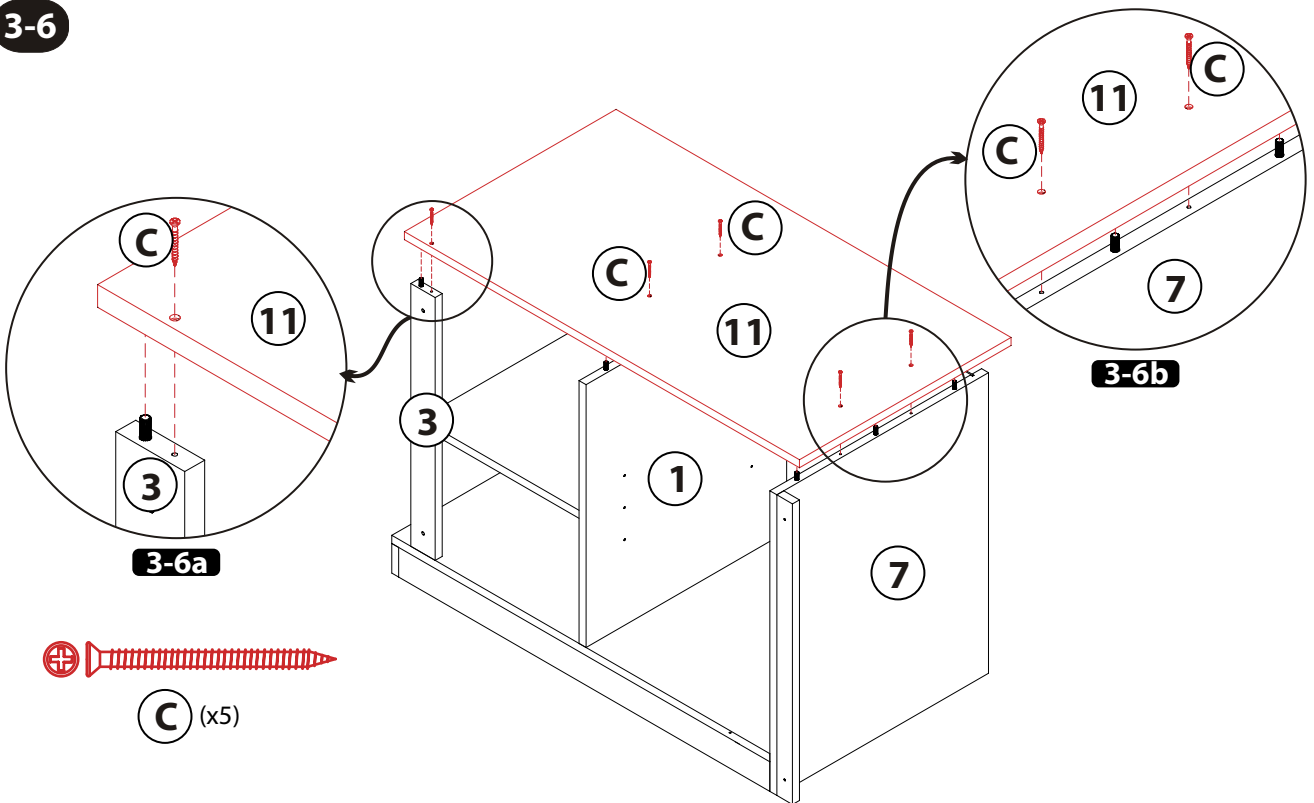

Attach panel (11) onto unit. Make sure all dowels are inserted and the panel is flush with unit. Secure with screws (C) as shown.

STEP 3 - SHELF ASSEMBLY

3-7



(C) (x9)

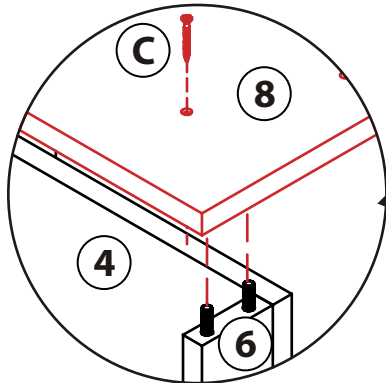

3-7a

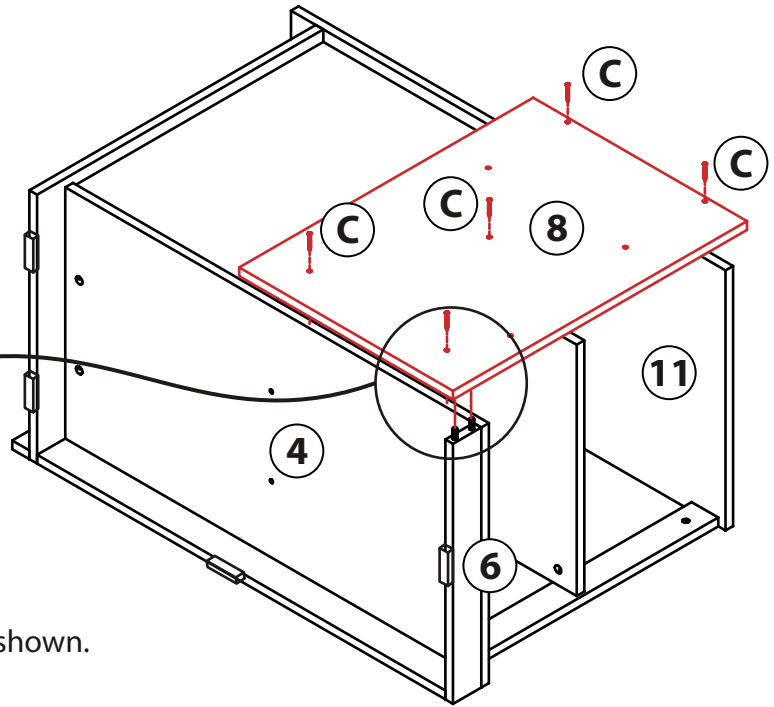

Tighten panel (8) with screw (C) as shown.
Shelf assembly complete.

STEP 4 - BED ASSEMBLY

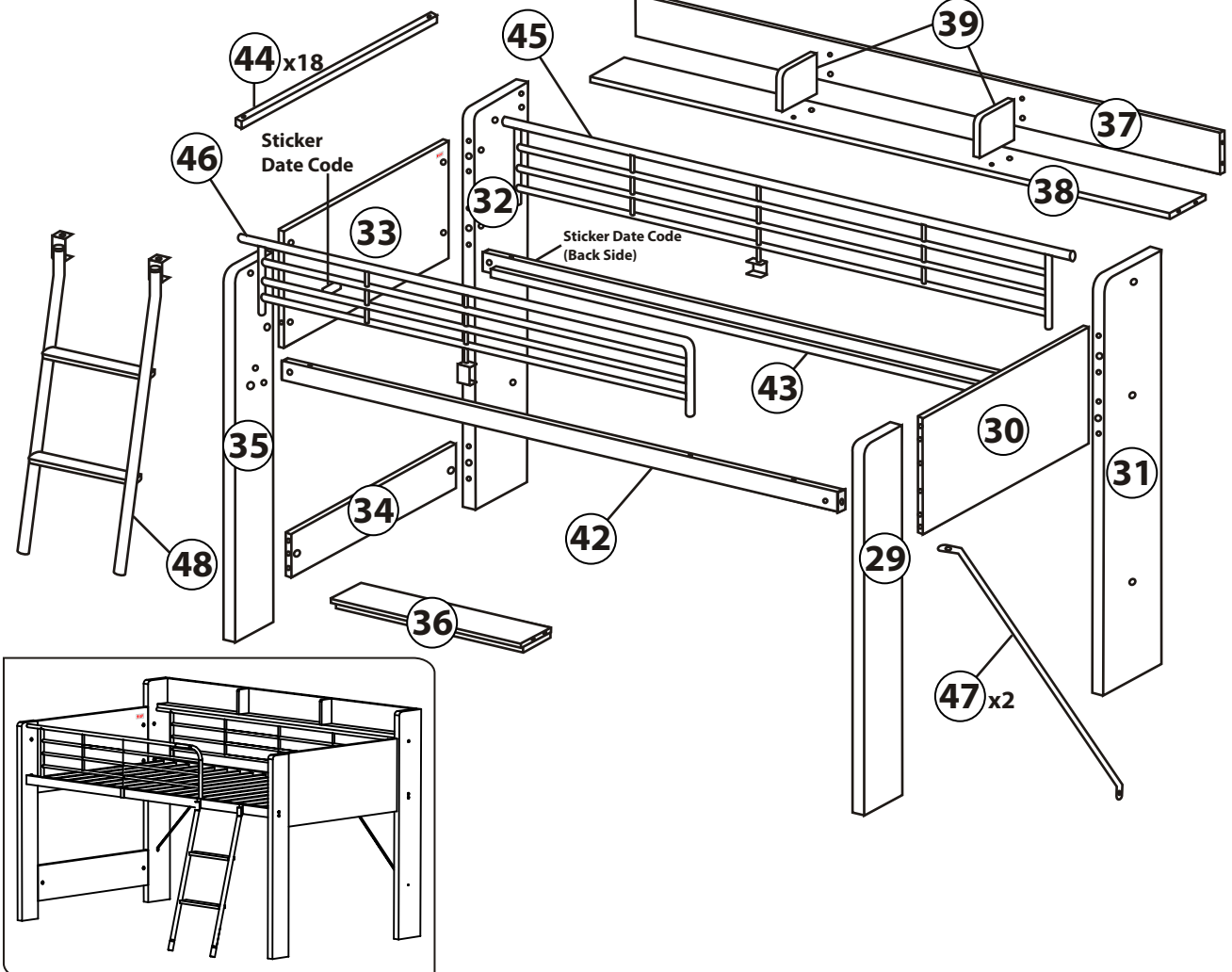

STEP 4 - BED ASSEMBLY

Hardware needed to assemble the Bed

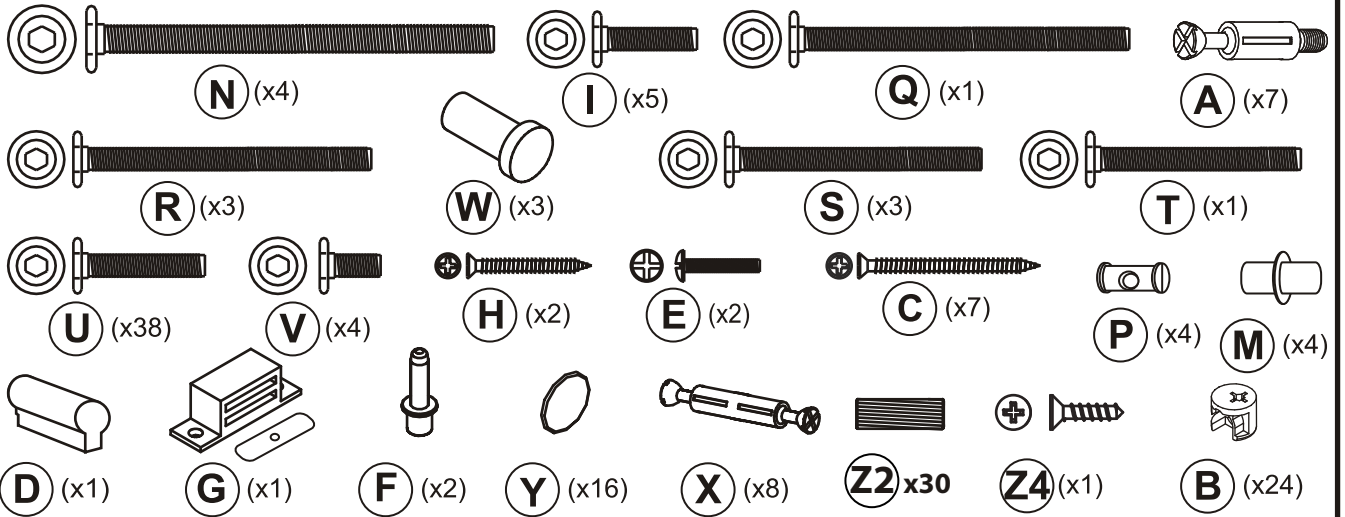

Assemble the wood dowels, cam locks and cam bolts first as per the diagram below.

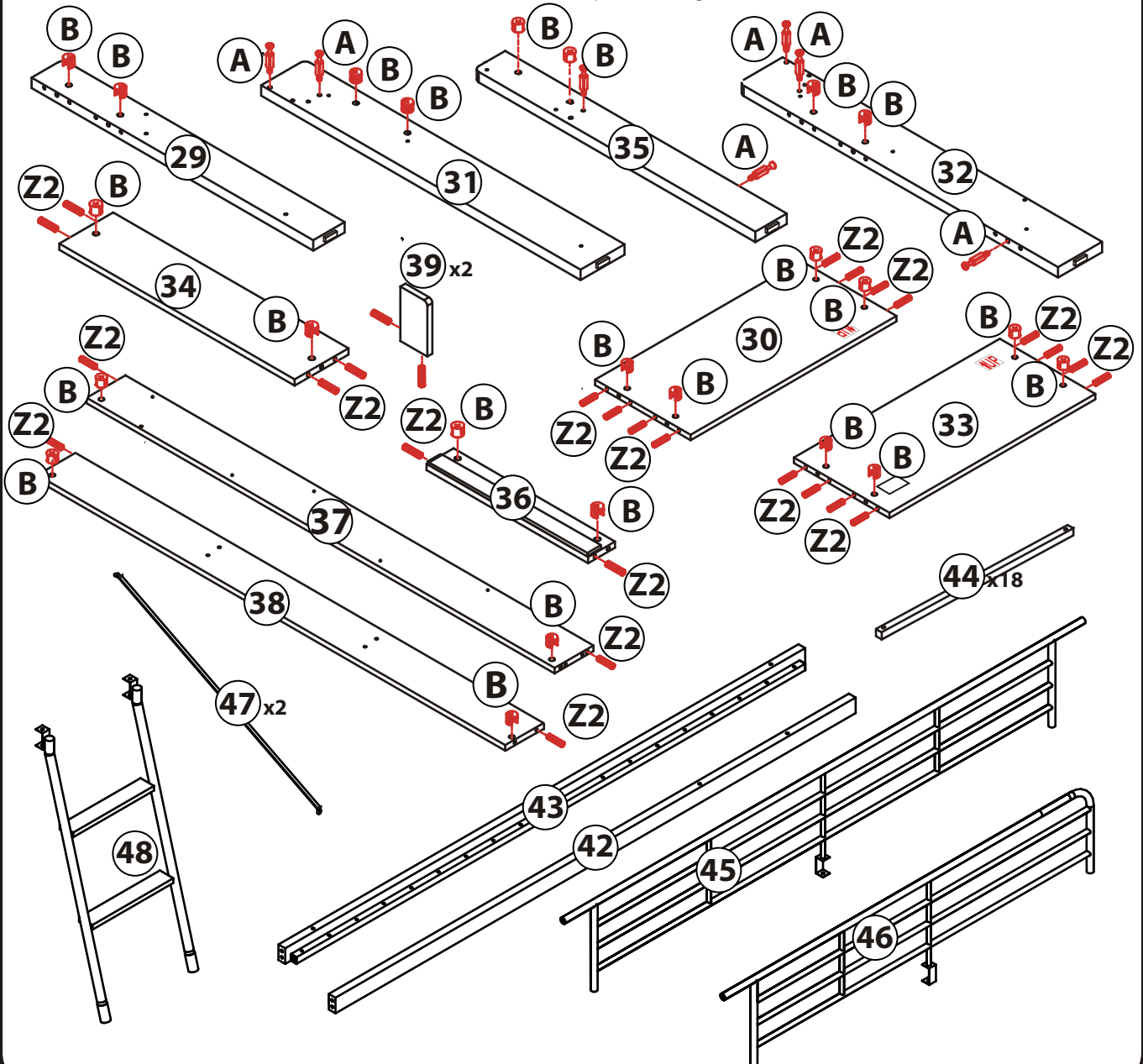

STEP 4 - BED ASSEMBLY

4-1

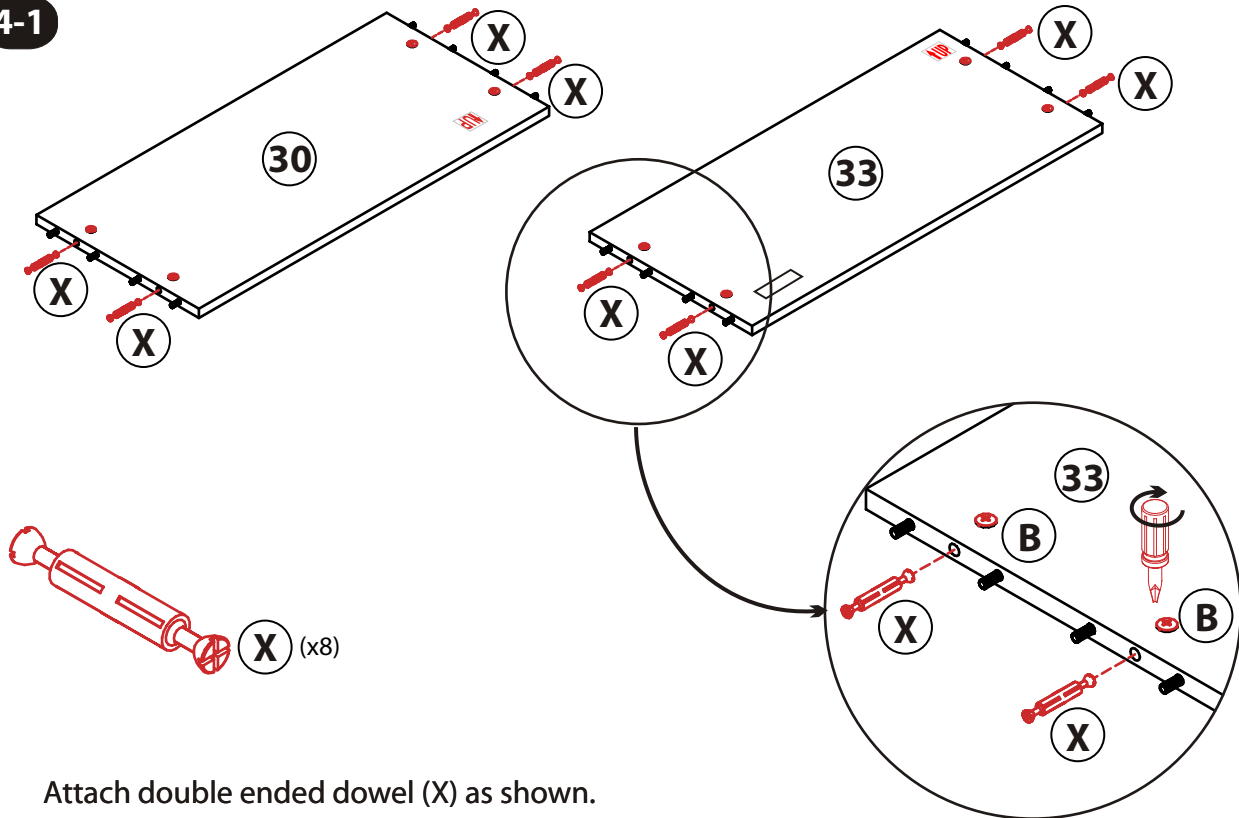

Attach double ended dowel (X) as shown.

4-1a

4-2

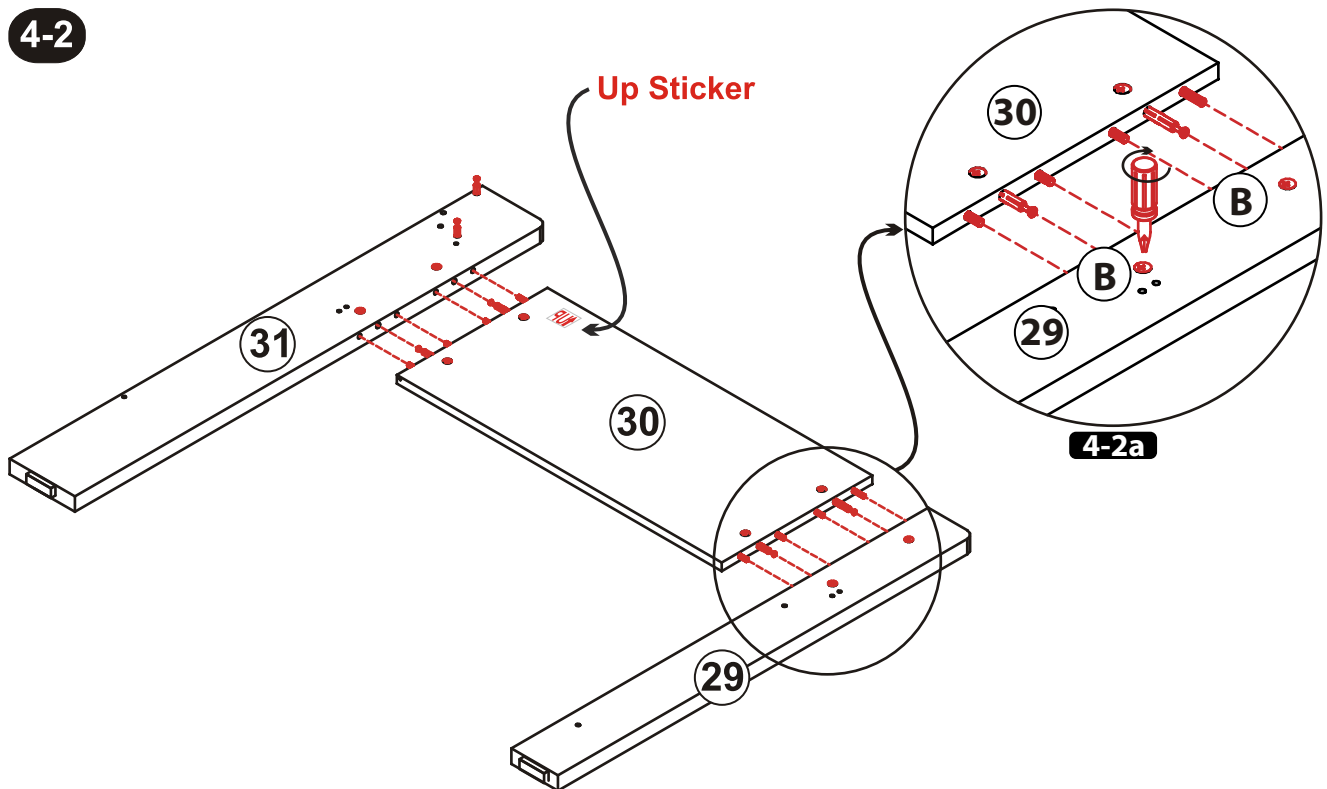

Tighten left and right panel (29 & 31) to center panel (30) as shown.

STEP 4 - BED ASSEMBLY

4-3

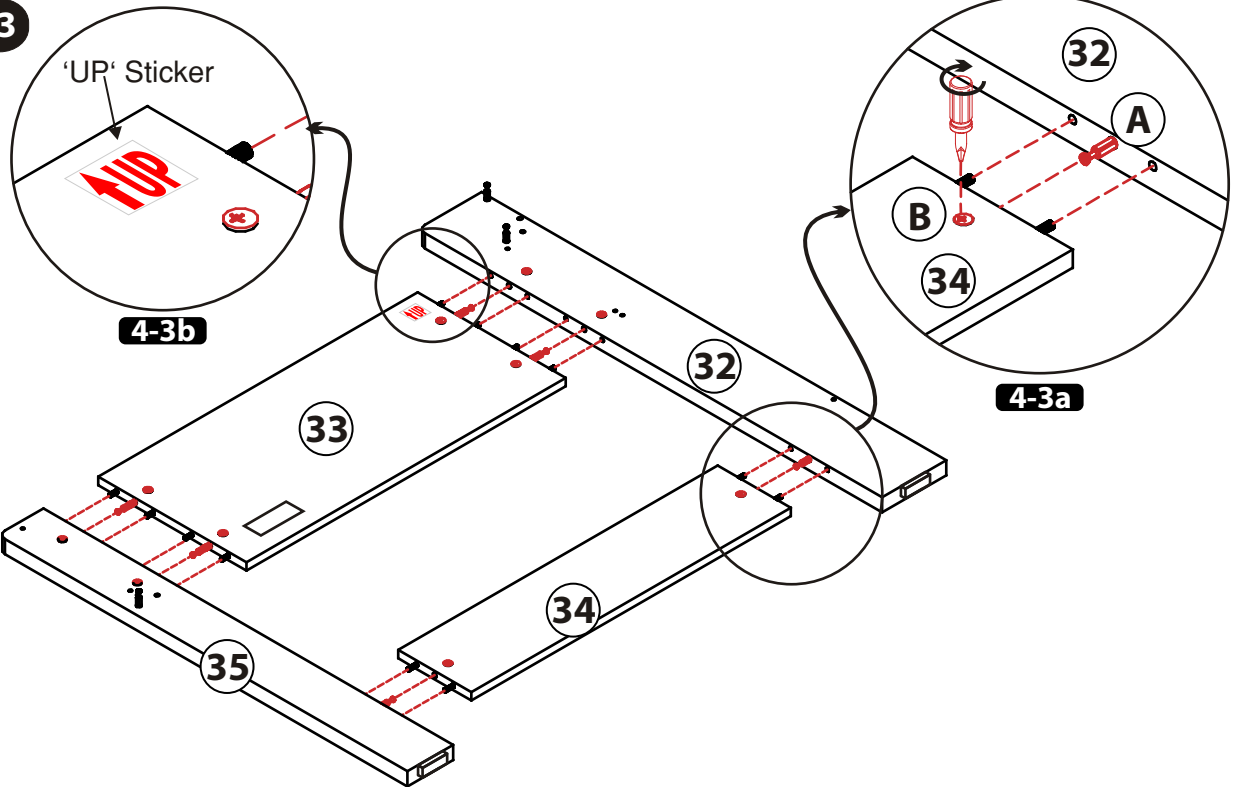

Insert panel (34) along with panel (33) as shown.
Then tighten left and right panel (32 & 35) to center panel (33 & 34) as shown.

4-4

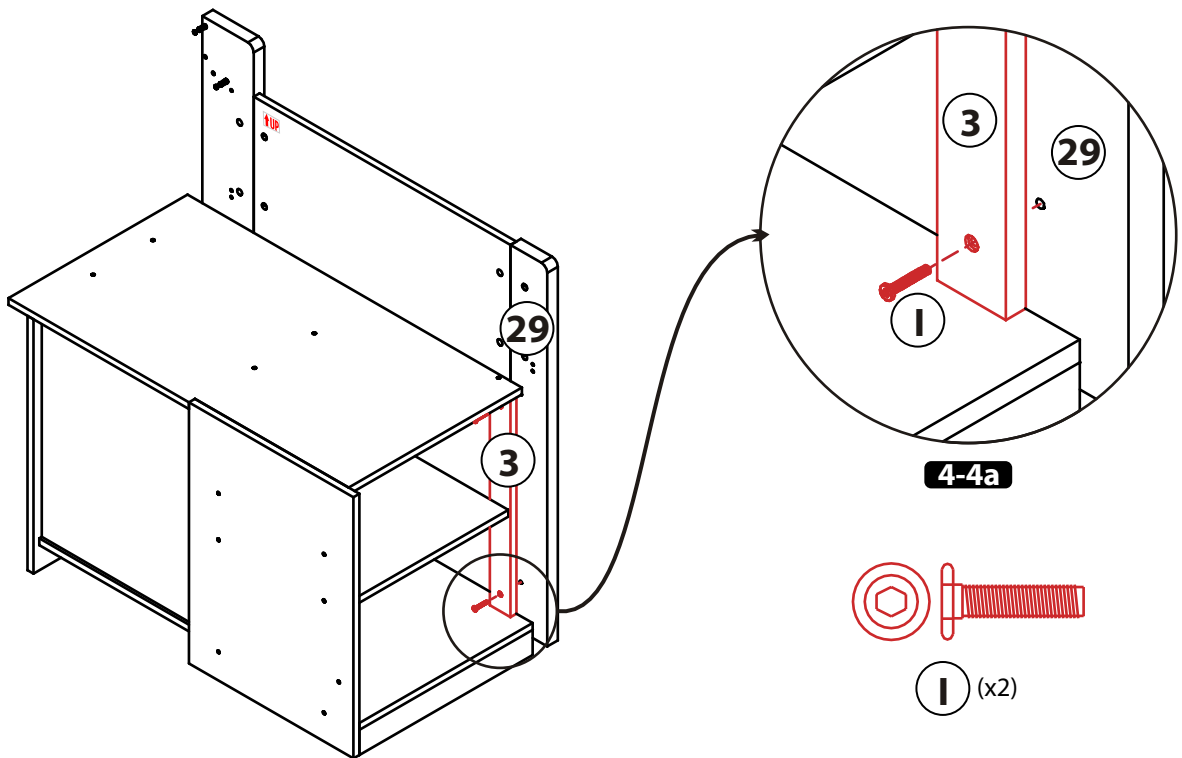

Tighten panel (3) with allen bolt (I) as shown.

STEP 4 - BED ASSEMBLY

4-5

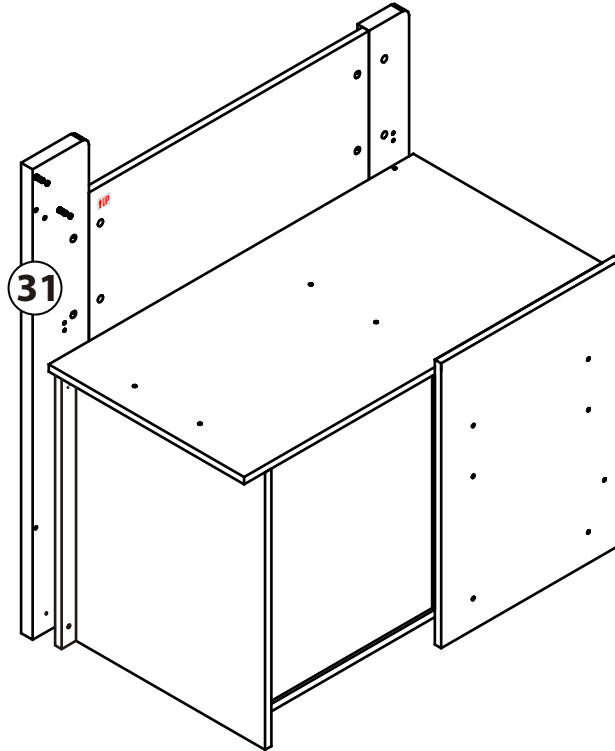

Put Up

4-6

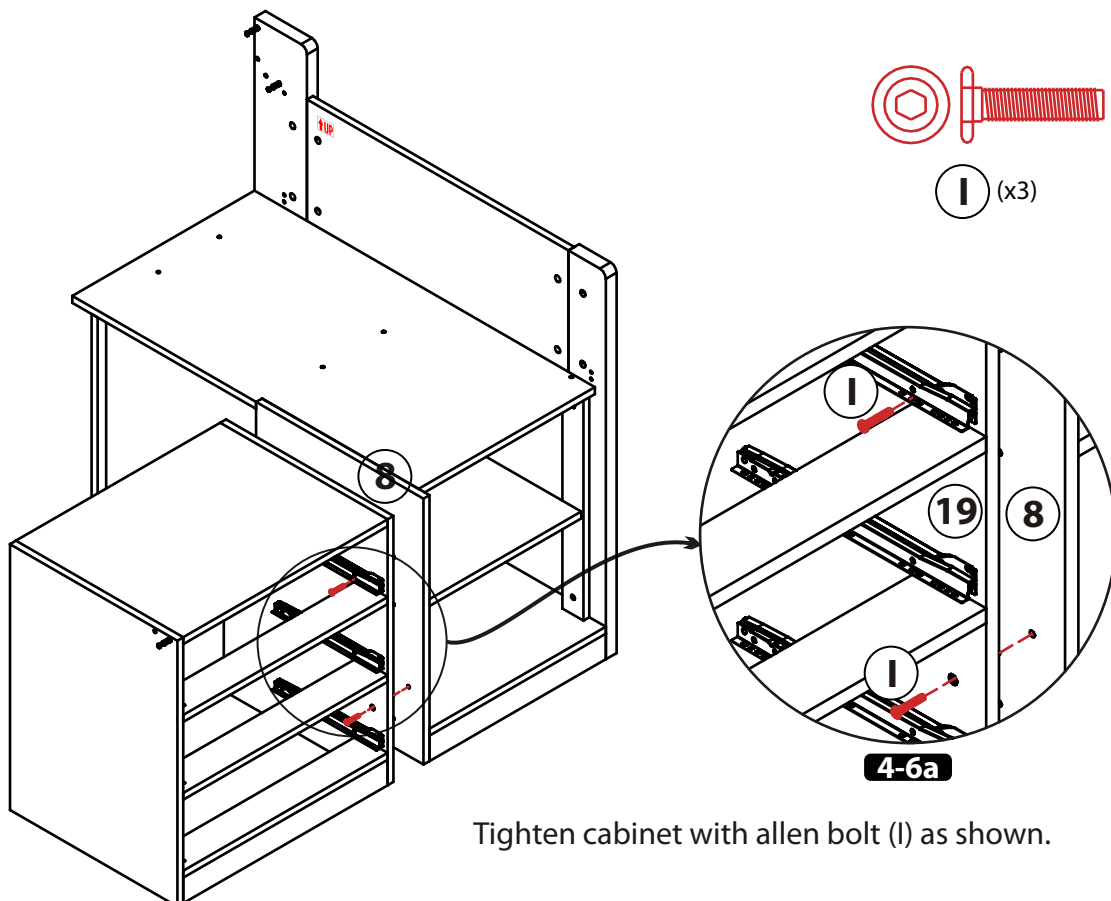

STEP 4 - BED ASSEMBLY

4-7

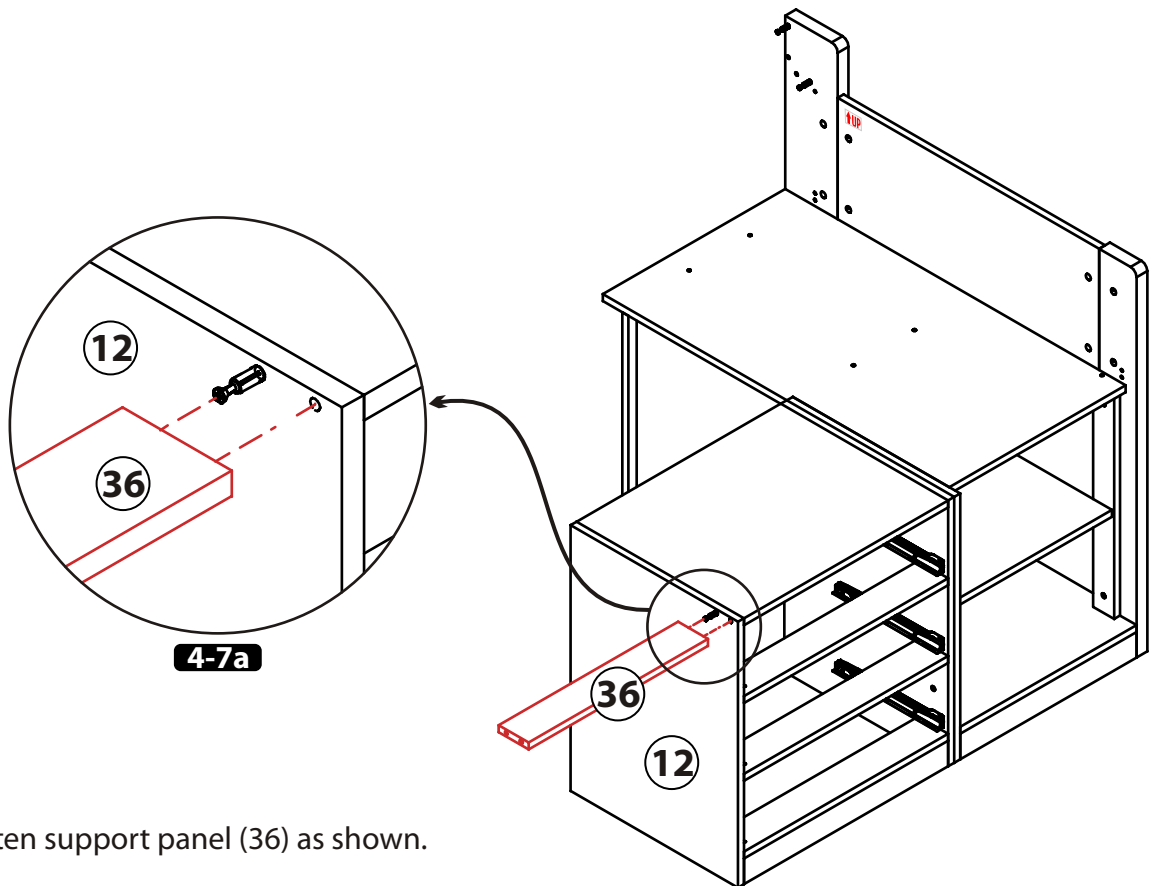

Tighten support panel (36) as shown.

4-8

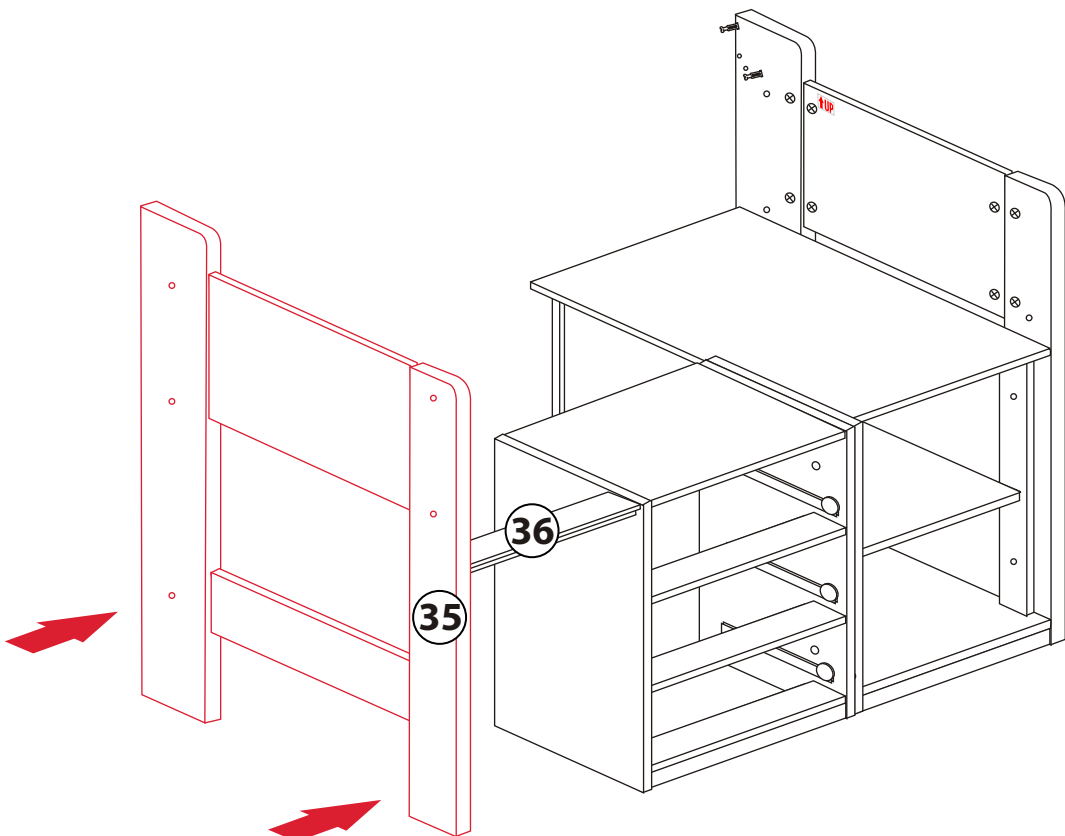

Tighten end panel as shown.

STEP 4 - BED ASSEMBLY

4-9

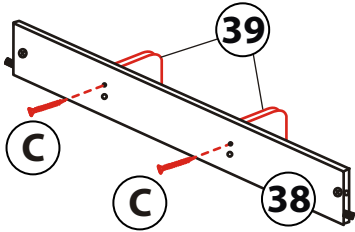

4-9a

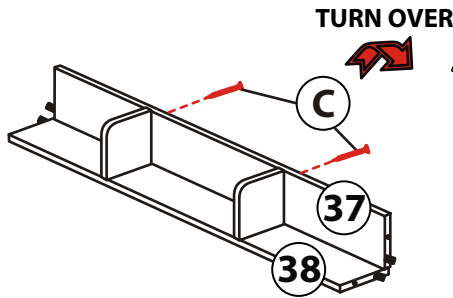

4-9b

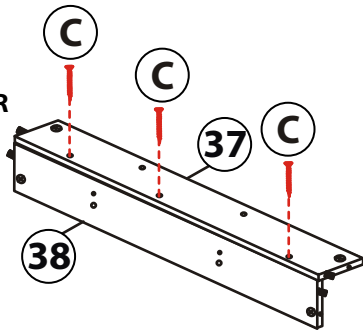

4-9c

Tighten shelf (39) to panel (38) with screw (C) as shown in 4-9a.

Tighten panel (37) with screw (C) as shown in 4-9b. Then tighten panel 38 with screw (C) as shown in 4-9c.



(C) (x7)

4-10

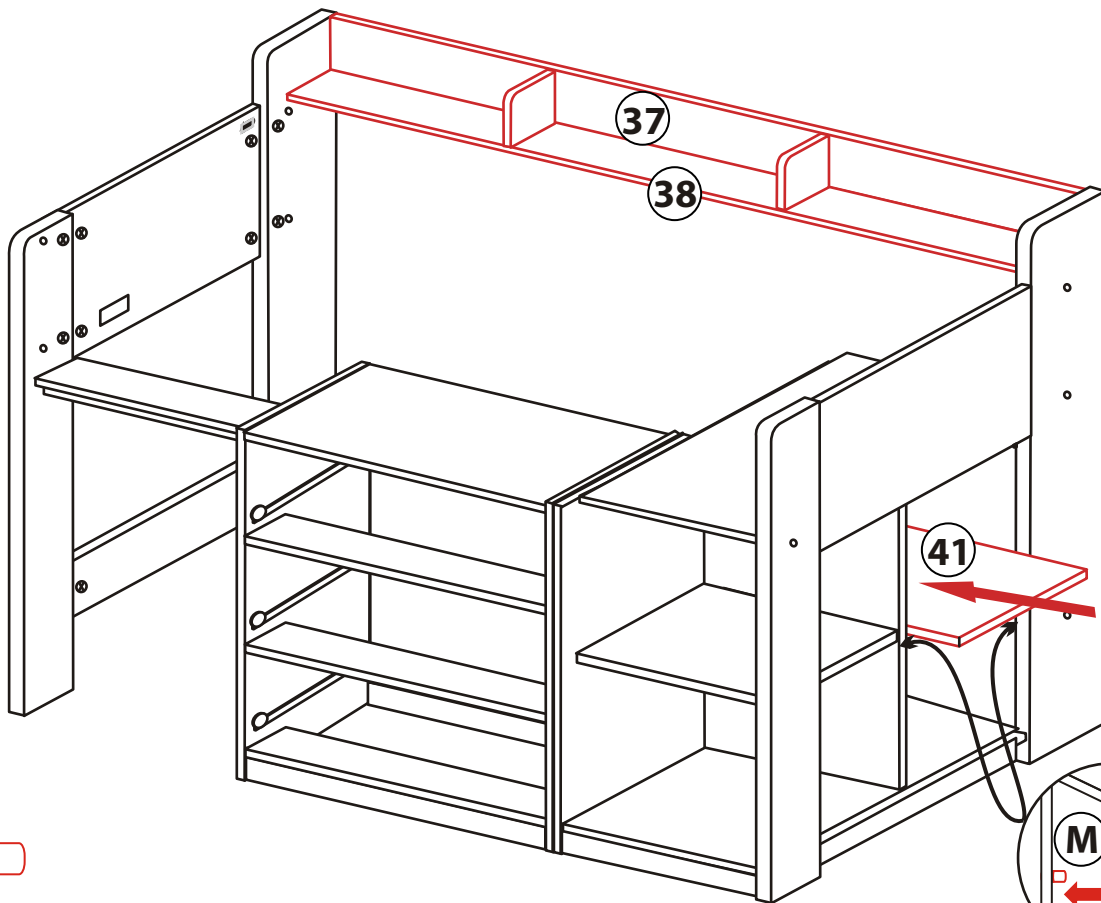

(M) (x4)

Tighten panel to left and right end panel as shown. Then push in movable panel (41) as shown.

STEP 4 - BED ASSEMBLY

4-11

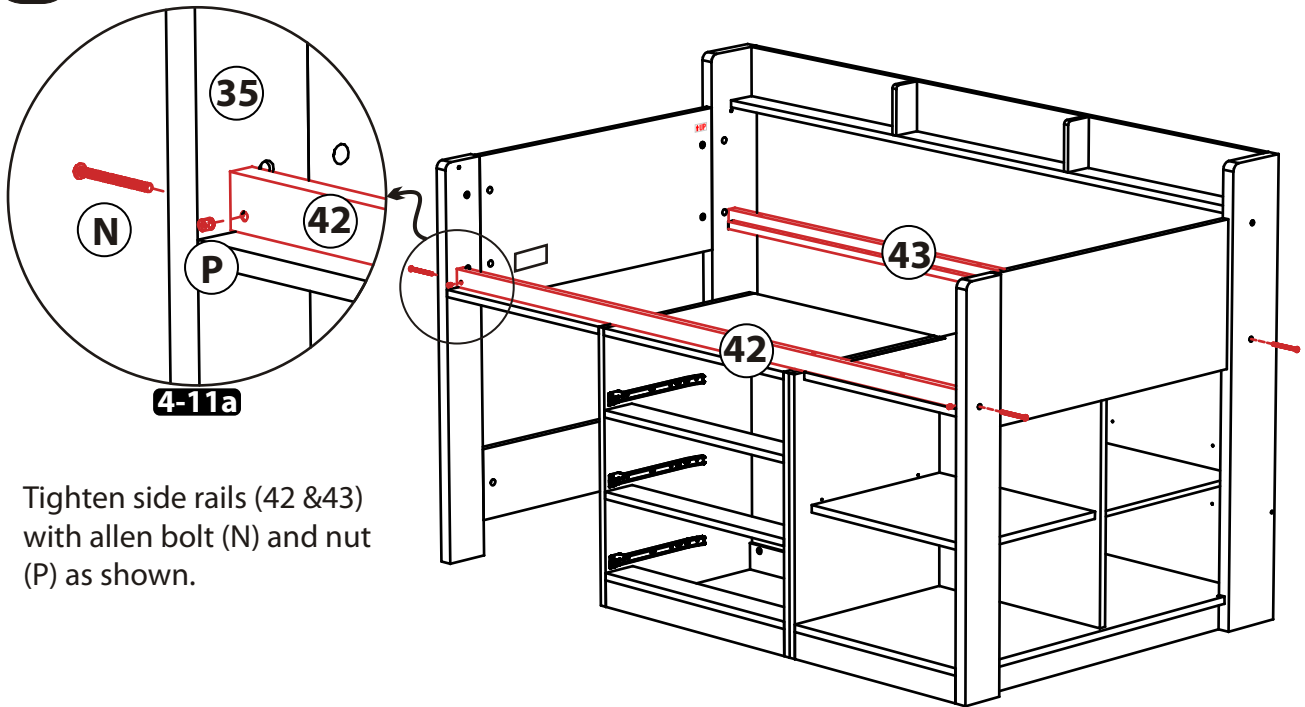

Tighten side rails (42 & 43) with allen bolt (N) and nut (P) as shown.



(N) (x4)



(P) (x4)

4-12

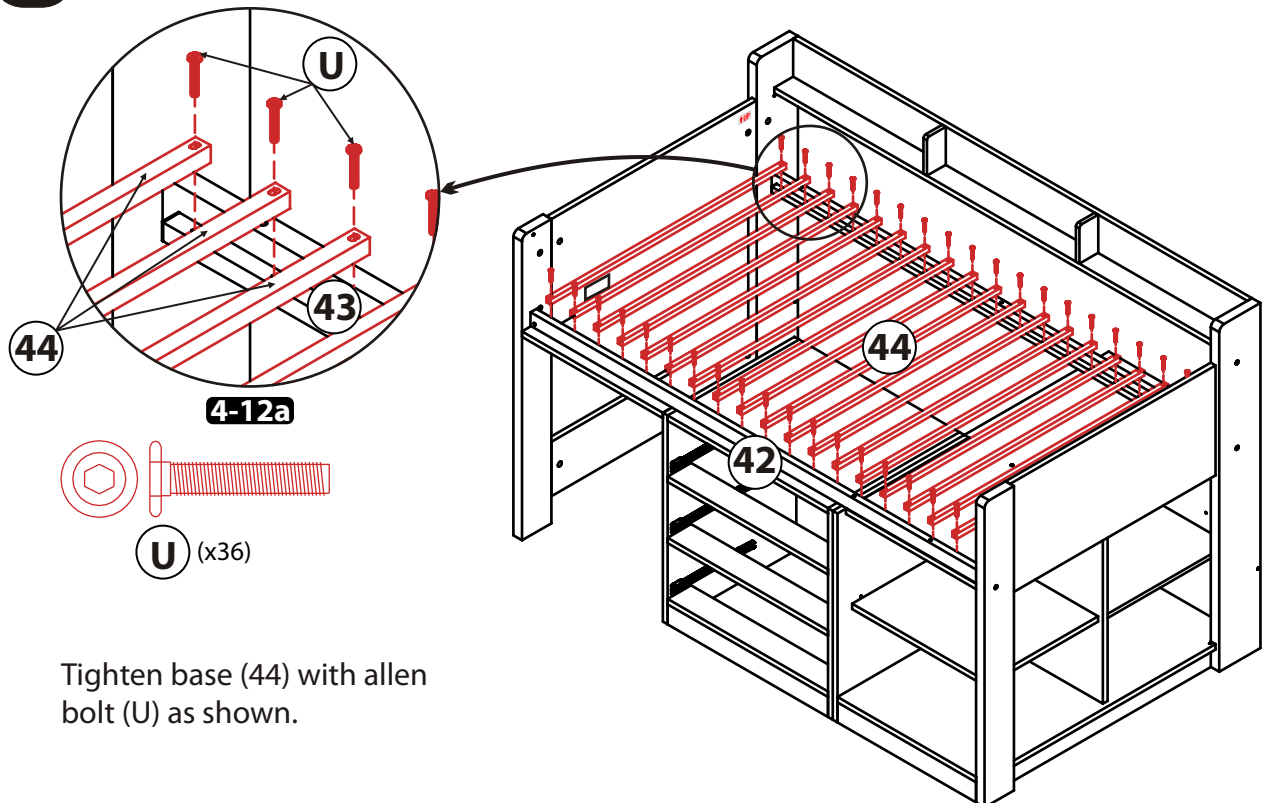

Tighten base (44) with allen bolt (U) as shown.

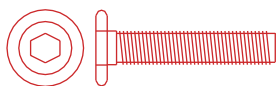

(U) (x36)

STEP 4 - BED ASSEMBLY

4-13

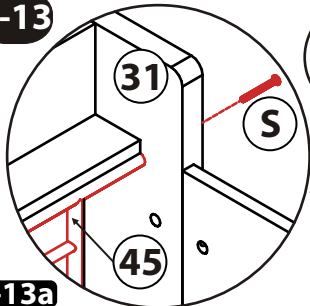

Front View

4-13a

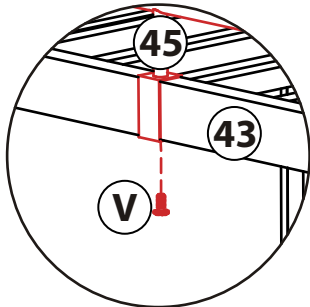

4-13b

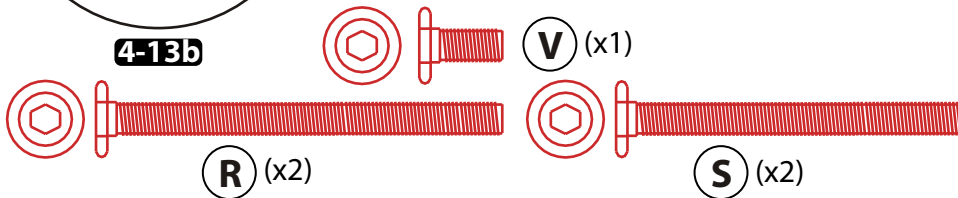

Tighten guardrail (45) with allen bolt (R,S,V) as shown.

4-13c

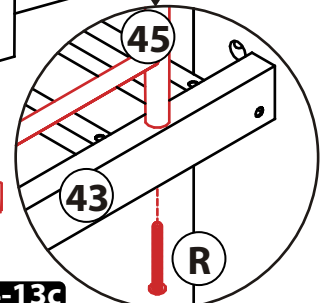

Front View

4-14

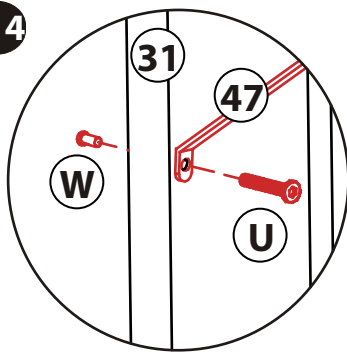

4-14a

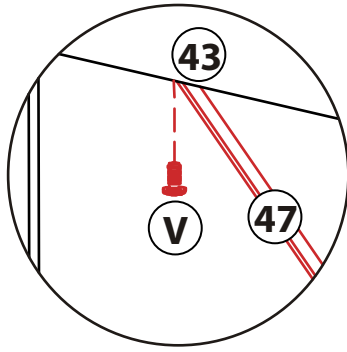

4-14b

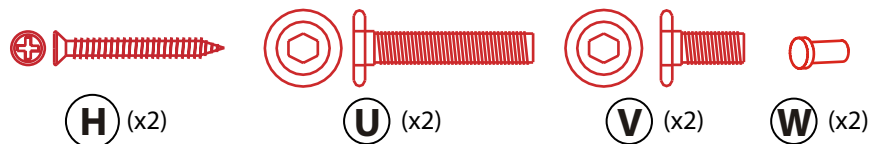

Tighten brace (47) with allen bolt (V) to base as shown 4-14b, Tighten panel (9) with screw (H) as shown. Then tighten brace (47) with allen bolt (U) and JCN (W) to side panel as shown 4-14a.

STEP 4 - BED ASSEMBLY

4-17

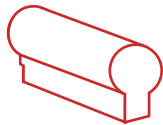
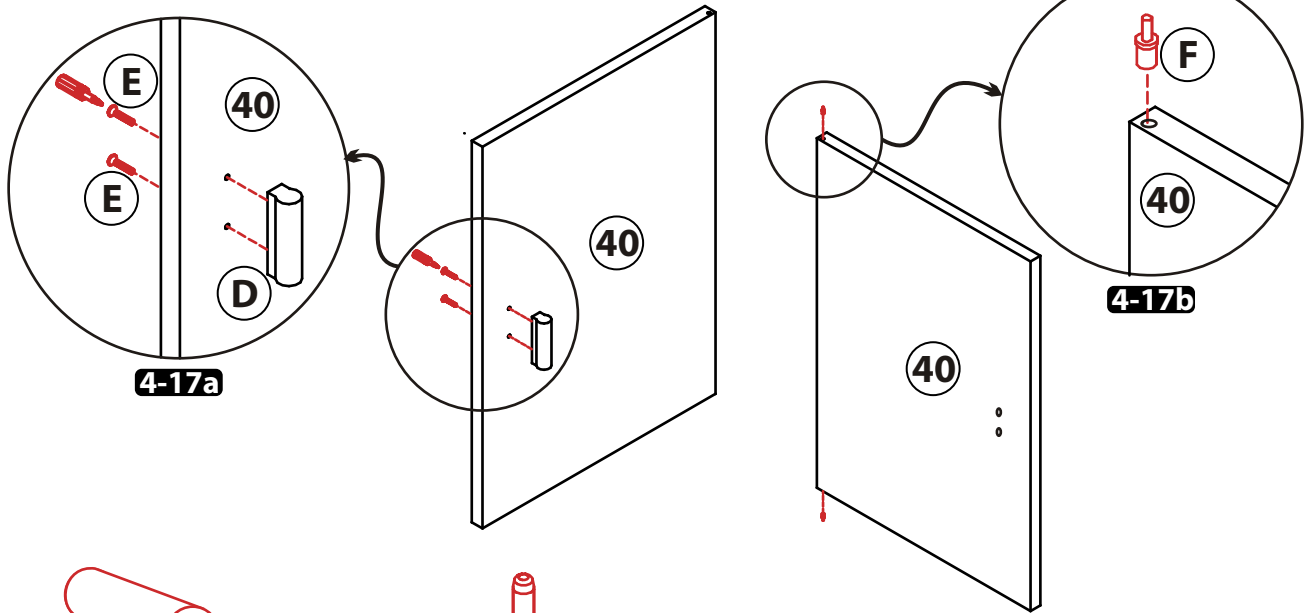

(D) (x1)



(E) (x2)



(F) (x2)

Attach handle (D) with screw (E) as shown in 4-17a.

Attach PVC door spring (F) to door panel (40) as shown 4-17b.

4-18

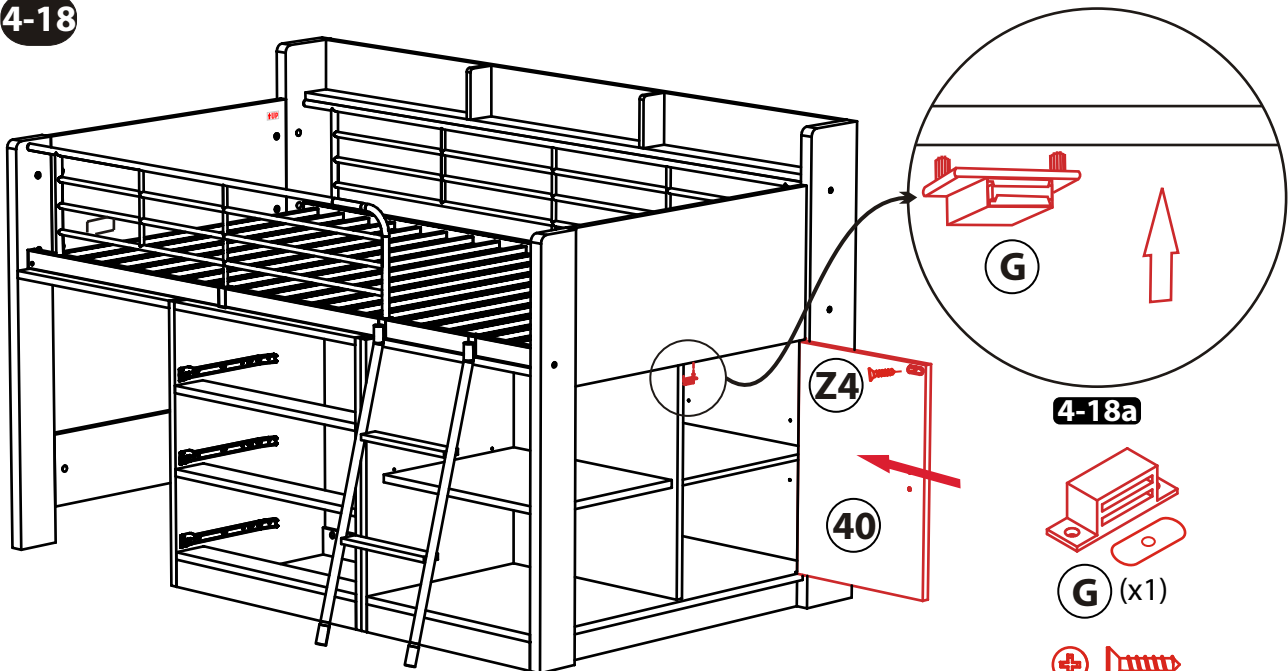

(G) (x1)



(Z4) (x1)

Insert the door panel into cabinet as shown. Then attach magnet (G) as shown.

STEP 4 - BED ASSEMBLY

4-17

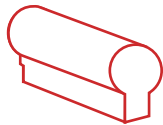
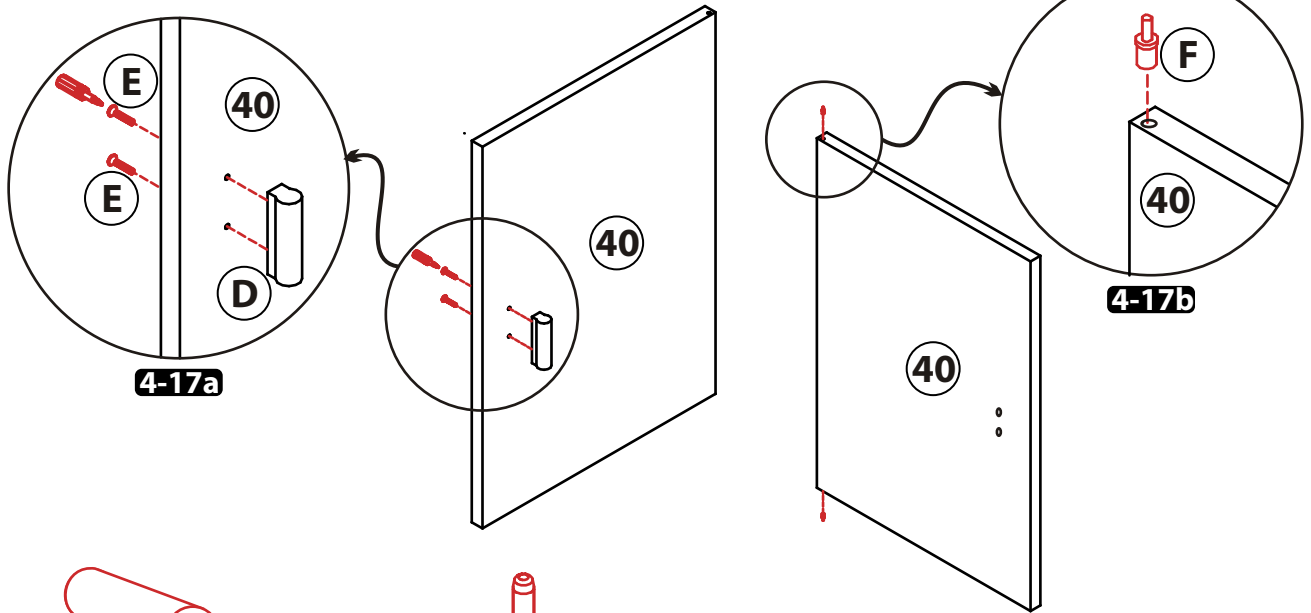

(D) (x1)



(E) (x2)



(F) (x2)

Attach handle (D) with screw (E) as shown in 4-17a.

Attach PVC door spring (F) to door panel (40) as shown 4-17b.

4-18

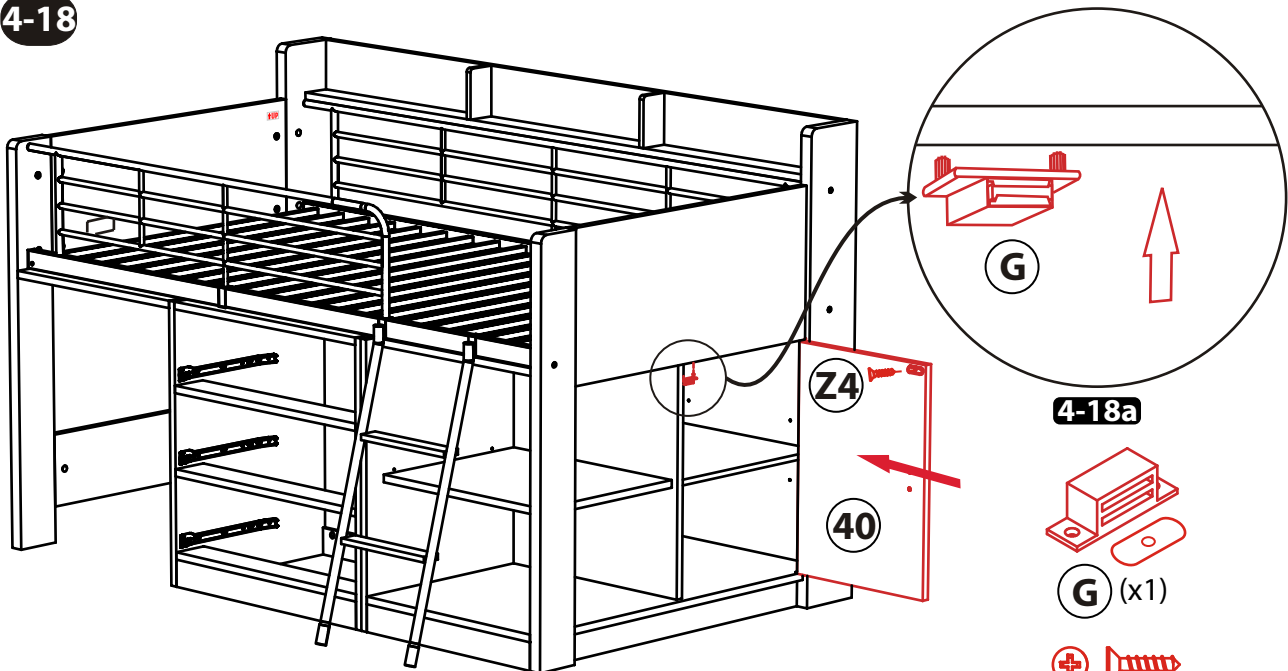

(G) (x1)



(Z4) (x1)

Insert the door panel into cabinet as shown. Then attach magnet (G) as shown.

STEP 4 - BED ASSEMBLY

4-19

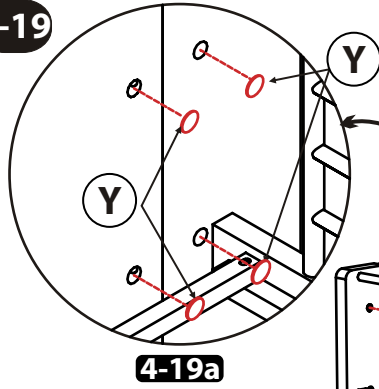

 (Y) (x16)

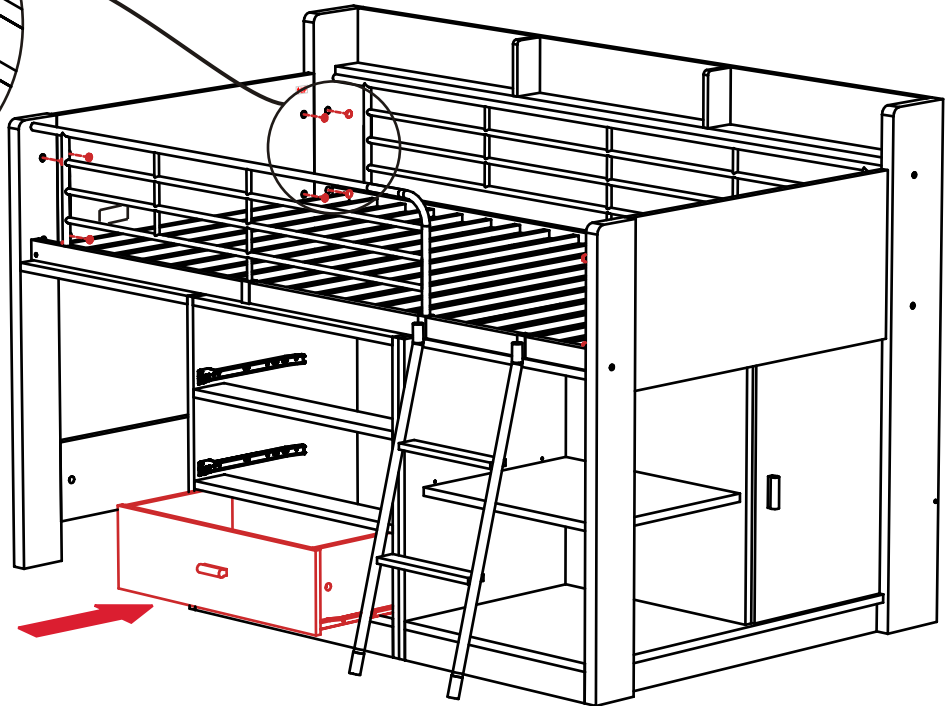

Slide drawers into the dresser assembly as shown. Then attach Stickers (Y) to cover the cams (B).

4-20

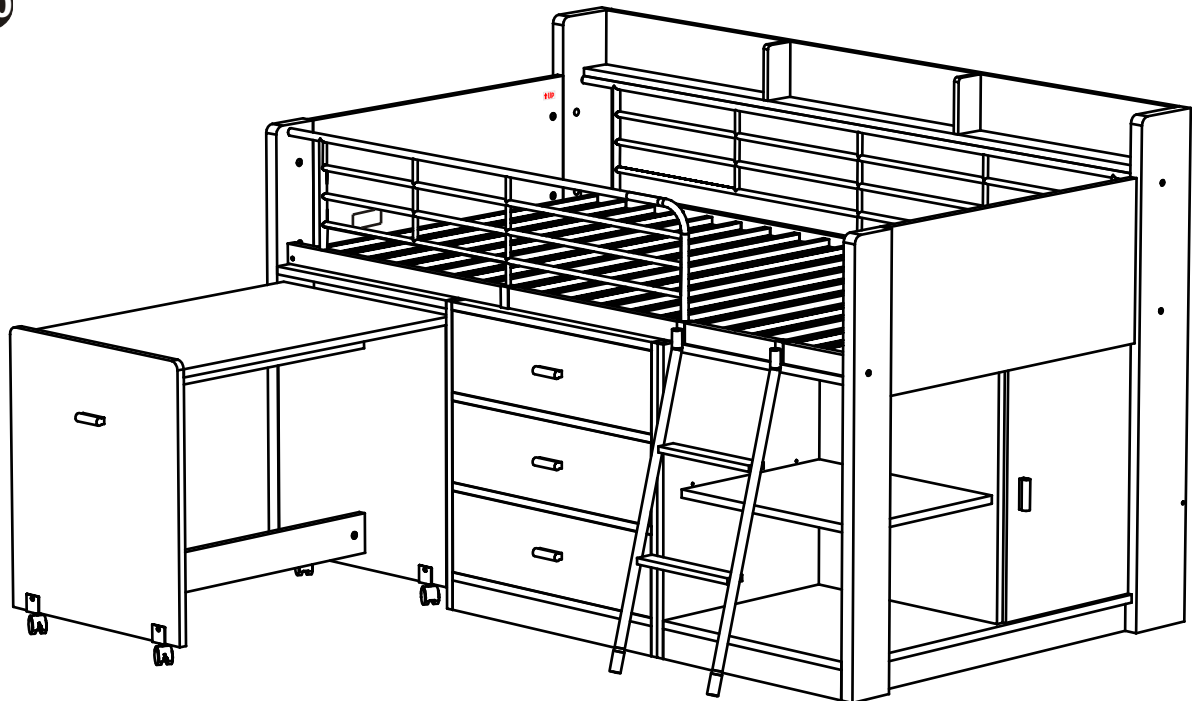

Assembly is complete. Make sure that all of the hardware is tightened and secure.

Please use this area to make notes on assembly or where you stored the hardware when item is disassembled.

Rack Furniture
Suite 1, 2713 SE I Street,
Bentonville, AR 72712 USA



Customer Service: 1-479-715-6445
www.rackfurniturellc.com

Product Packaging Information

Master Model #: _____

Box Model #: _____

Color: _____

Shipment Ref. #: _____

Date: _____

MADE IN MALAYSIA